

NXP TDA11136PC305CG SERIES

SERVICE MANUAL

COLOUR TELEVISION

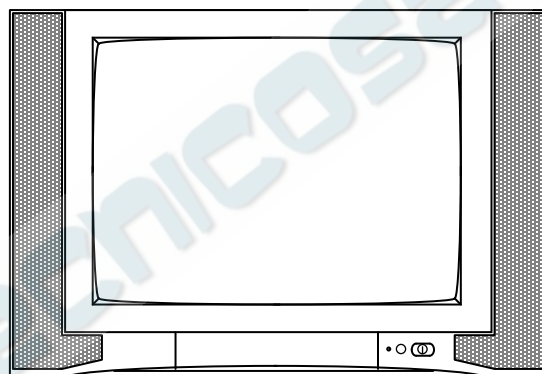

www.TECHNICOSLAURIOS.COM

SAFETY PRECAUTIONS

- The design of this product contains special hardware, many circuits and components specially for safety purposes. For continued protection, no changes should be made to the original design unless authorized in writing by the manufacturer. Replacement parts must be identical to those used in the original circuits. Service should be performed by qualified personnel only.
- Alterations of the design or circuitry of the products should not be made. Any design alterations or additions will void the manufacturer's warranty and will further relieve the manufacturer of responsibility for personal injury or property damage resulting therefrom.
- Many electrical and mechanical parts in the products have special safety-related characteristics. These characteristics are often not evident from visual inspection nor can the protection afforded by them necessarily be obtained by using replacement components rated for higher voltage, wattage, etc. Replacement parts which have these special safety characteristics are identified in the parts list of Service manual. **Electrical components having such features are identified by shading on the schematics and by (!) on the parts list in Service manual.** The use of a substitute replacement which does not have the same safety characteristics as the recommended replacement part shown in the parts list of Service manual may cause shock, fire, or other hazards
- Don't short between the LIVE side ground and ISOLATED (NEUTRAL) side ground or EARTH side ground when repairing.** Some model's power circuit is partly different in the GND. The difference of the GND is shown by the LIVE: () side GND, ISOLATED (NEUTRAL) : () side GND and EARTH : () side GND. Don't short between the LIVE side GND and ISOLATED (NEUTRAL) side GND or EARTH side GND and never measure with a measuring apparatus (oscilloscope etc.) the LIVE side GND and ISOLATED (NEUTRAL) side GND or EARTH side GND at the same time. If above note will not be kept, a fuse or any parts will be broken.
- If any repair has been made to the chassis, it is recommended that the B1 setting should be checked or adjusted (See ADJUSTMENT OF B1 POWER SUPPLY).
- The high voltage applied to the picture tube must conform with that specified in Service manual. Excessive high voltage can cause an increase in X-Ray emission, arcing and possible component damage, therefore operation under excessive high voltage conditions should be kept to a minimum, or should be prevented. If severe arcing occurs, remove the AC power immediately and determine the cause by visual inspection (incorrect installation, cracked or melted high voltage harness, poor soldering, etc.). To maintain the proper minimum level of soft X-Ray emission, components in the high voltage circuitry including the picture tube must be the exact replacements or alternatives approved by the manufacturer of the complete product.
- Do not check high voltage by drawing an arc. Use a high voltage meter or a high voltage probe with a VTVM. Discharge the picture tube before attempting meter connection, by connecting a clip lead to the ground frame and connecting the other end of the lead through a 10kΩ 2W resistor to the anode button.
- When service is required, observe the original lead dress. Extra precaution should be given to assure correct lead dress in the high voltage circuit area. Where a short circuit has occurred, those components that indicate evidence of overheating should be replaced. Always use the
- manufacturer's replacement components.
- Isolation Check (Safety for Electrical Shock Hazard)**
After re-assembling the product, always perform an isolation check on the exposed metal parts of the cabinet (antenna terminals, video/audio input and output terminals, Control knobs, metal cabinet, screwheads, earphone jack, control shafts, etc.) to be sure the product is safe to operate without danger of electrical shock.
- The surface of the TV screen is coated with a thin film which can easily be damaged. Be very careful with it when handle the TV. Should the TV screen become soiled, wipe it with a soft dry cloth. Never rub it forcefully. Never use any cleaner or detergent on it.

(1) Dielectric Strength Test

The isolation between the AC primary circuit and all metal parts exposed to the user, particularly any exposed metal part having a return path to the chassis should withstand a voltage of 3000V AC (r.m.s.) for a period of one second.

(...Withstand a voltage of 1100V AC (r.m.s.) to an appliance rated up to 120V, and 3000V AC (r.m.s.) to an appliance rated 200V or more, for a period of one second.) This method of test requires a test equipment not generally found in the service trade.

(2) Leakage Current Check

Plug the AC line cord directly into the AC outlet (do not use a line isolation transformer during this check.). Using a "Leakage Current Tester", measure the leakage current from each exposed metal part of the cabinet, particularly any exposed metal part having a return path to the chassis, to a known good earth ground (water pipe, etc.). Any leakage current must not exceed 0.5mA AC (r.m.s.).

However, in tropical area, this must not exceed 0.2mA AC (r.m.s.).

●Alternate Check Method

Plug the AC line cord directly into the AC outlet (do not use a line isolation transformer during this check.). Use an AC voltmeter having 1000 ohms per volt or more sensitivity in the following manner. Connect a 1500 Ω 10W resistor paralleled by a 0.15 μ F AC-type capacitor between an exposed metal part and a known good earth ground (water pipe, etc.). Measure the AC voltage across the resistor with the AC voltmeter. Move the resistor connection to each exposed metal part, particularly any exposed metal part having a return path to the chassis, and measure the AC voltage across the resistor. Now, reverse the plug in the AC outlet and repeat each measurement. Any voltage measured must not exceed 0.75V AC (r.m.s.). This corresponds to 0.5mA AC (r.m.s.).

However, in tropical area, this must not exceed 0.3V AC (r.m.s.).

This corresponds to 0.2mA AC (r.m.s.)

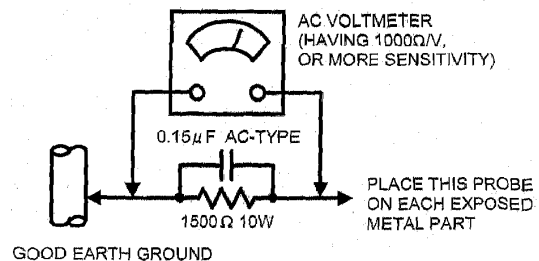

TV Block diagram

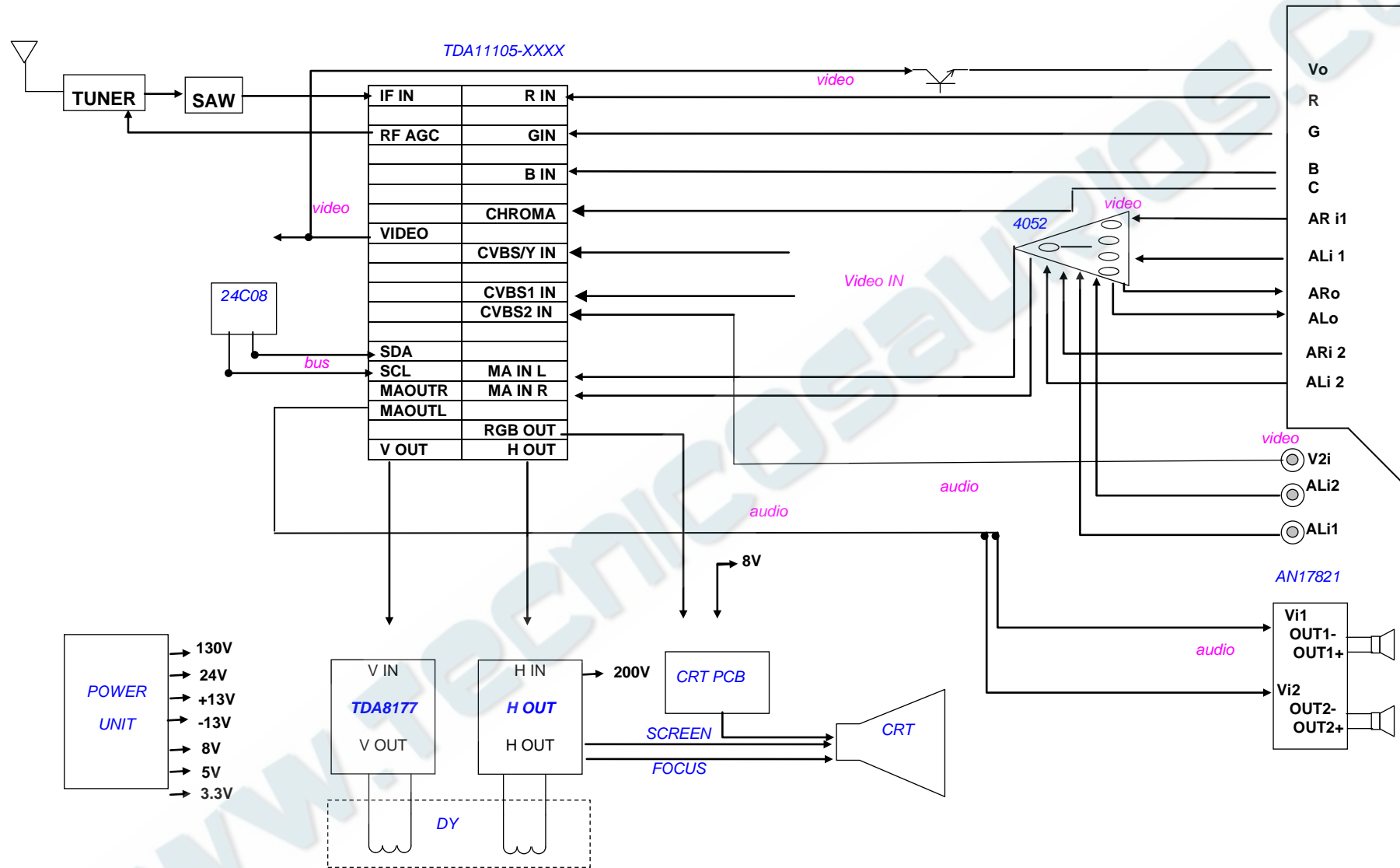

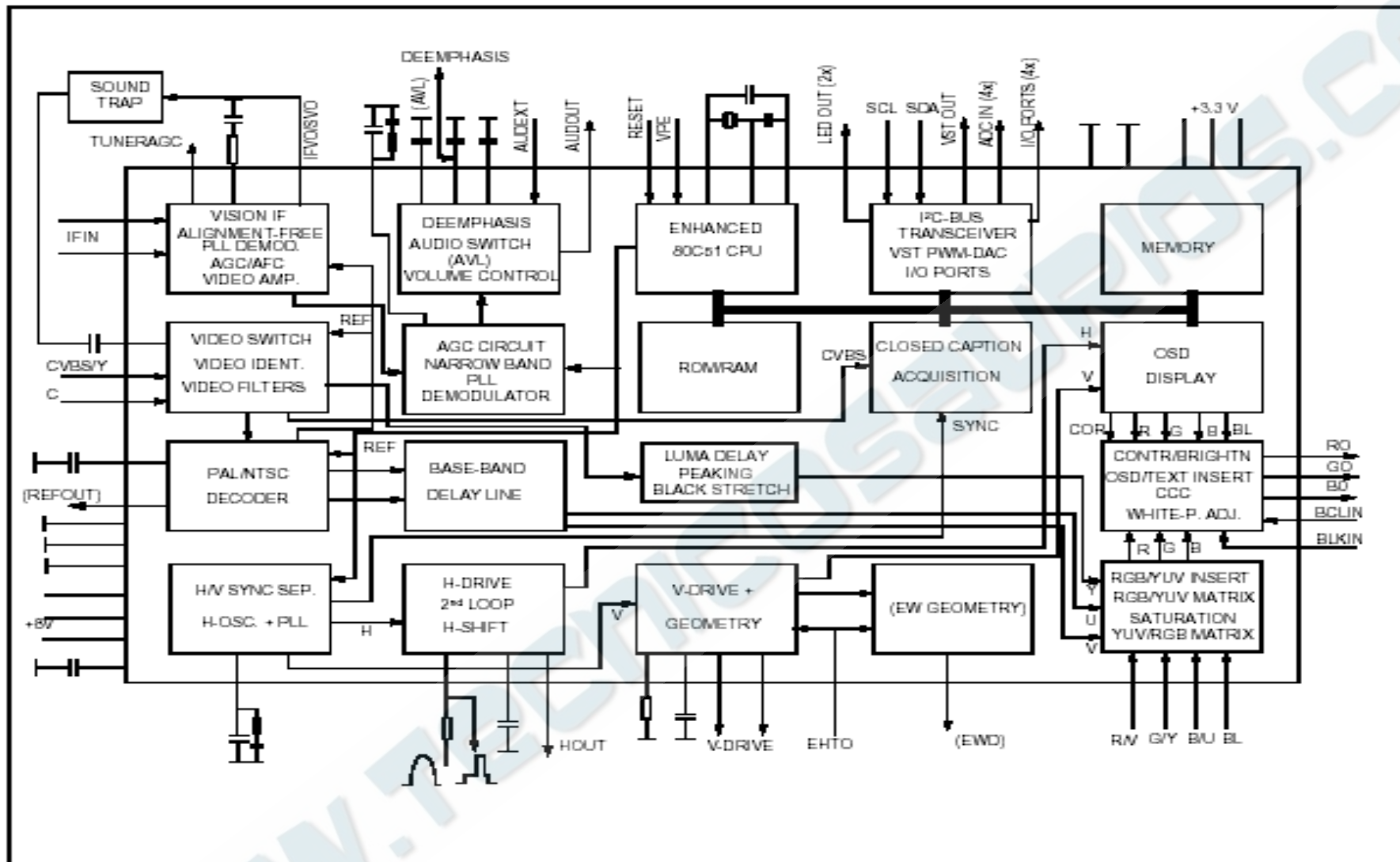

BLOCK DIAGRAM

REPLACEMENT OF MEMORY IC

1. MEMORY IC.

This TV uses memory IC. In the memory IC are memorized data for correctly operating the video and deflection circuits.

When replacing memory IC, be sure to use IC written with the initial value of data.

2. PROCEDURE FOR REPLACING MEMORY IC

(1) Power off

Switch the power off and unplug the power cord from AC outlet.

(2) Replace IC

Be sure to use memory IC written with the initial data values.

(3) Power On

Plug the power cord into the AC outlet and switch the power On.

(4) Check and set SYSTEM default value:

3. Note: enter a factory mode method

- 1) Factory remote control: Press the factory remote control up [PRESET], press again [TEST] key, appear on the television screen 'M'.
- 2) Customer remote control
- 3) Press [menu] key, appear the picture menu, press few character keys 6483, the screen appears M.
- 4) Press [standby] key, withdraw factory mode.
- 5) The "TEST" will be displayed on the screen.
- 6) Check the setting value of the SYSTEM default value of Table below. If the value is different, select items by [CH+]/[CH-] keys and set value by [VOL+]/[VOL-] keys.
- 7) Press "STANDBY" key again and return to the normal screen.

SERVICE ADJUSTMENT

B1 POWER SUPPLY

1. Receive normal colour bar signal.
2. Connect DC voltmeter to D551- and isolated ground.
3. Adjust potentiometer in power unit to get the voltage as 110V \pm 1.0V for 21 inch hereinafter, 130 \pm 1.0V for 25 inch upwards.

FOCUS ADJUSTMENT

1. Receive a crosshatch signal.
2. While watching the screen, adjust the FOCUS VR to make the vertical and horizontal lines as fine and sharp as possible.

BUS CONTROL ADJUSTMENT

To enter BUS control mode, Press "TEST" key on the Remote control unit of factory. (Customer remote control press "MENU" key behind in a row press "6""4""8""3")

Choose a "SETUP SELECT" options in "M2" menu, Change "SETUP SELECT 0" to "SETUP SELECT 1", press "MUTE" key again can depend on this get into "M3"~"M9" of design menu, general factory the

production doesn't need to carry on M 3~ adjustments of M9.

In "M0"~under"M9" appearance press" CALL" the key can get into "M" appearance.

At "M"under the appearance press "-/-" the key can get into "BUS OPEN" appearance, at "BUS OPEN under, press "-/-" the key recover factory appearance.

Remote Hand Unit keys

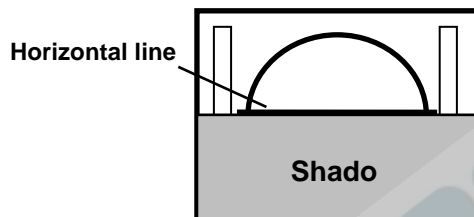
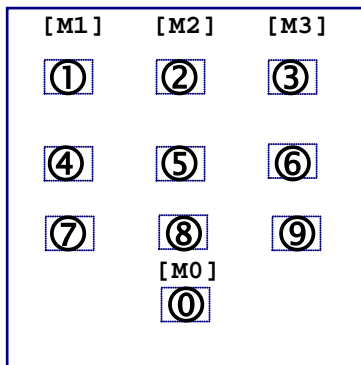

[M1] menu

MENU0 Geometrical adjustment

Receive PAL standard Complete pattern signal.

Adjustment steps :

- Adjust V. SLOPE, to the center horizontal line just appear from half bottom shadow.
- Adjust V. SIZE, to get 90% of vertical picture contents would be displayed on CRT.
- Adjust V. SHIFT, the center horizontal line correspond to CRT vertical center.
- Adjust H.SHIFT, to get the picture horizontal center correspond to CRT horizontal center.

Receive NTSC signal and repeat above [M0] and [M1] adjustment.

[M2] Menu

AGC Adjustment.

Receive $60\text{dB}\mu(1\text{mV})V_H$ colour bar pattern signal , adjust AGC value (voltage from high to low) , to noise reduce gradually and just disappeared point.

Select "shipping", push [V+] [V-]key to be shipped.

[M3] Menu

CRTcut off and white balance adjustment.

Receive white signal.

- CRT cut off adjustment.
 - Select "SC", then automatically vertical scan will be stopped.
 - Adjust SCREEN control on Flyback transformer to get the darkest single horizontal line (red, green, or blue, sometimes shows more yellow, more purple or more white).
- White balance adjustment.
 - Select RD/BD menu.
 - Adjust RD/BD to get colour temperature as $x=281, y=311$
- Sub-Brightness adjustment. (Use stair case signal)
 - Select SB menu.

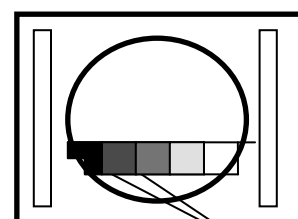

2. Adjust SB to get the darkest step being cutoff.

I²C standard UOC for export bus control adjustment item default setting 2007-12-05

MI	Items	Variable		Preset	recommendation	
		50HZ	60HZ		50HZ	60HZ
	TEST.SE	0/1		Choice of test signal		
	V. SLOPE	63	+/-32	Picture vertical center adjustment	35	-01
	V. POSI	63	+/-32	Vertical positions adjustment	40	-1
	V. SIZE	63	+/-32	Vertical amplitude adjustment	20	+02
	V. SC	63	+/-32	Vertical S Correction Adjustment	25	-01
	V.LINE	63	+/-32	Vertical line Adjustment	18	+02
	V.SCR	63	+/-32	Vertical S Correction R	32	-01
	H.PSASE	15	+/-32	Horizontal position adjustment	40	0
	EW.W	63	+/-32	Horizontal amplitude adjustment	55	0
	EW.PW	63	+/-32	E/W amplitude adjustment	29	0
	EW.TC	63	+/-32	Picture trapezoid adjustment	31	0
	EW.UCP	63	+/-32	Picture top Cape adjustment	48	0
	EW.LCP	63	+/-32	Picture bottom Cape adjustment	45	0
	H.BOW	63	+/-32	Picture bow form adjustment	30	0
	H.PAR	63	+/-32	Picture parallelogram adjustment	31	0
	H.BLK.SW	ON/OFF		Horizontal blank switch	ON	
	H .BLK.L	15	+/-7	Horizontal left blank adjust	0	
	H .BLK.R	15	+/-7	Horizontal right blank adjust	0	
	V . X	63	+/-32	Vertical zoom step	20	
	RGB	63	+/-32	RBG hor. offset	32	
M1		TV /DVD				
	CL	0~15		Contrast level offset	10	
	BLOC	0~15		Black level offset course	6	
	R.BIA	0~63		R OUT Amplitude Adjustment	32	
	G.BIA	0~63	32	G OUT Amplitude Adjustment	32	-6
	B.BIA	0~63		B OUT Amplitude Adjustment	32	
	R.DRV	0~63		R OUT Amplitude Adjustment	32	
	G.DRV	0~63		G OUT Amplitude Adjustment	32	
	B.DRV	0~63		B OUT Amplitude Adjustment	32	
	SUB BRT	0~63		Brightness of screen line	32	
	VSD	0~1		Vertical Ramp Out Stop Selection		
	TEST.S	0~5				
M2		50HZ	60HZ			
	RF AGC	0~63		32 Tuner AGC Takeover Point Adjustment	18	
	OSD.V.POS	0~63	0~63	Vertical position of OSD	16	22
	OSD.H.POS	0~63		Horizital position of OSD	9	
	OSD BRT	0~15		OSD brightness	15	

SHIPPING				
	SETUP SELECT	0~1	Select 1, press the MUTE key to M 3~ M9	
M3	SUB CONT	0~63	Sub contrast	63
	SUB COLOR	0~63	Sub colour	63
	SUB SHARP	0~63	Sub sharpness	63
	SUB TINT	0~63	Sub tint	32
	BTC	0~63		32
	COF	0~1	Cut-off control range 0:normal control range 1:extended control range	1
	FRENCH	ON/OFF	OSD language selection	ON
	TURKISH	ON/OFF	OSD language selection	ON
	PORTUGUESE	ON/OFF	OSD language selection	ON
	BULGARINA	ON/OFF	OSD language selection	ON
	RUSSIAN	ON/OFF	OSD language selection	ON
	FARSI	ON/OFF	OSD language selection	ON
	ARABIC	ON/OFF	OSD language selection	ON
	RUMANIAN	ON/OFF	OSD language selection	ON
	SPANISH	ON/OFF	OSD language selection	ON
	HUNGARIAN	ON/OFF	OSD language selection	ON
	POLISH	ON/OFF	OSD language selection	ON
	CZECH	ON/OFF	OSD language selection	ON
	SLOVENE	ON/OFF	OSD language selection	ON
	CROATIAN	ON/OFF	OSD language selection	ON
	MACEDONIAN	ON/OFF	OSD language selection	ON
	SERBIAN	ON/OFF	OSD language selection	ON
	GREEK	ON/OFF	OSD language selection	ON
M4	VA	0~3	Vercital amplitude	0
	VAI	0~1	System I output signal amplitude correction 0:no correction 1:amplitude + 12%	1
	CBS	0~1	Control sequence of beam current limiting 0:normal operation(contrast—brightness) 1:control on contrast and brightness in parallel	1
	COR	0~1	Video dependent coring(peaking) 0:off 1:coring active between 0 and 20 IRE	0
	RPA	0~3	Ratio pre-and aftershoot	2
	RPO	0~3	Ratio of positive and negative peaks	2
	TCI2X	0~1	Top sync clamp current of the CVBS/Y input clamp 0: clamp current about 80 uA 1: clamp current about 160 uA	0
	BKS	ON/OFF	Baack stretch	ON
	BSD	0~1	Black stretch Depth 0:15IRE 1:30 IRE	0

	AAS	0~3	Black area to switch off the black stretch	0
	PWL	0~1	Peak white limiting 0:peak white limiting circuit not active 1:peak white limiting circuit active	
	SOC	0~1	Soft clip adjust	0
	PWLDAC	0~15	Peak white adjust	2
	CHSE	0~15	Color degree identifies an intelligent degree	2
	S.IDENT	ON/OFF	S-VIDEO Identify switch	ON
	TFR	0~1	Transfer ratio 0:no black level shift due to video content 1:black level shift 10 IRE for a white picture	0
	DSK	0~1	Dynamic skin control on/off 0:off 1:on	0
	DSA	0~1	Dynamic skin tone angle 0:123 1:117	0
	WS	0~1		0
	BLS	0~1	Blue stretch mode 0:off 1:on	0
	GAME	ON/OFF	Game switch	ON
	CALENDAR	ON/OFF	CALENDAR switch	
M5	IF		Vision IF of RF (38/38.9/45.75/58.75) MHZ	38.9MHZ
	OIF	0~63	IF compensate	32
	FFI	0~1	Fast filter IF -PLL	0
	AGCS	0~3	AGC speed	0
	DCXO	0~3	Crystal load electric capacity compensate	2
	FSL	0~1	Forced slicing level for vertical sync	0
	SSL	0~1	Slicing level for horizontal sync separator 0:50% 1:30%,direction top sync	0
	GD	0~1	Group delay on CVBSI signal 0:no group delay correction 1: group delay correction switched on	0
	HP2	0~1	Sync hronization of OSD/TEXT display	0
	AKB	ON/OFF	Black current stabilization	OFF
	DFL	0~1	Disable flash protection from deflection timer 0:restart horizontal output,after flash protection, via slow start 1: restart horizontal output,after flash protection,with typical duty-cycle	0
	XDT	0~1	x-ray detection on/off	0
	FBC	0~1	Fixed beam current switch off	0
	QDT	0~1		0
	FBC1	0~1	Fixed beam current during switch off 0:fixed beam current is 1 mA 1:fixed beam current is 2 mA	0
	FSPS	0~1	Selection of left or right hand side in split-Screen mode	0
	FSPB	0~1	Blanking in split-screen mode	0
	FSPE	0~1	Enable split-screen mode for demonstration of features	0

	HCO	0~1	EHT tracking mode	0
	OSVE	0~1	Black current measuring lines in overscan(for vertical zoom setting'1)	0
	EVB	0~1	Extended vertical blanking	0
	IFS.RED	0~1	IF Intelligent degree	1
	PWM.VOL	ON/OFF		OFF
	MUTE MODE	0~2	0: internal + external control 1: control 2: external control	
M6	CLF	0~1	Selection internal clamp speed 0:clamp slow 1:clamp 6 times faster	0
	BPB	0~1	Enable bypass of sound bandpass filter at mono mode 0:sound bandpass active for mono demodulator 1:sound bandpass filter bypassed	0
	BPB2	0~1	Bypass sound bandpass filter section 2 0:bandpass filter active 1:bandpass filter bypassed	0
	FMWS	0~3	Window select for FM demodulator	0
	AGN	0~1	Gain FM demodulator 0:normal operation 1:gain +6 dB	1
	AGNE	0~3	FM sound demodulator outopt signal amplitude	1
	AVL	ON/OFF	Auto volume levelling	OFF
	AVLE	0~1	AVL function on East-West output pin	0
	DSGLS	0~1	Extra gain selection loudspeaker outputs 0:+0 Db 1:+6 Db	0
	NRR	0~1	No red reduction during blue stretch	0
	AMLOW	0~1	Audio output signal for AM sound	0
	GSSIF	0~1	Extra gain-range SSIF for AM demodulation	0
	V.P1	0~100	V.P1 volume of VALUE	10
	V.P25	0~100	V.P25 volume of VALUE	45
	V.P50	0~100	V.P50 volume of VALUE	70
	V.P75	0~100	V.P75 volume of VALUE	85
	V.MAX	0~60	Volume max	
	ON DL	0~18	On delay time	3
	OFF DL	0~7	Off delay time	1
	ON/OFF MODE	0~1		0
M7	NAT		N-USA/PAL N-JPN/PAL N-USA/PAL PAL MAT	
	ACL	0~1	Automatic color limiting 0:not active 1:active	0
	CB	0~1	Chroma bandpass center frequency	0
	SBO	0~1	SECAM B-Y blank level offset adjustment	0
	BPS	0~1	Bypass of chroma base-band delay line 0:active 1:bypassed	0
	FCO	0~1	Forced Color-on 0:on 1:off	0

	DTR	0~1	Chroma trap mode 0:single chroma trap 1:dual chroma trap,more suppression but less bandwidth	0
	Y.P	0~15	Y-delay adjustment for PAL signal	8
	Y.N	0~15	Y-delay adjustment for NTSC signal	8
	Y.AV	0~15	Y-delay adjustment for PAL signal in AV mode	8
	Y.SVHS	0~15	Y-delay adjustment for PAL signal in S-video mode	8
	PF.P	0~3	PAL Center frequency with postpone adjust	0
	PF.N	0~3	NTSC Center frequency with postpone adjust	0
	PF.AV	0~3	AV Center frequency with postpone adjust	0
	C.PHI.1			
M8	S.BRT	0~100	Standard Brightness in pp mode	75
	S.CONT	0~100	Standard Contrast in pp mode	75
	S.COLOR	0~100	Standard Color in pp mode	50
	S.SHARP	0~100	StandardSharpness in pp mode	50
	D.BRT	0~100	dynamic Brightness in pp mode	75
	D.CONT	0~100	dynamic Contrast in pp mode	100
	D.COLOR	0~100	dynamic Color in pp mode	75
	D.SHARP	0~100	dynamicSharpness in pp mode	75
	M.BRT	0~100	mild Brightness in pp mode	40
	M.CONT	0~100	mild Contrast in pp mode	40
	M.COLOR	0~100	mild Color in pp mode	40
	M.SHARP	0~100	mildSharpness in pp mode	40
	W.BRT	0~100	factory adjusts Brightness	50
	W.CONT	0~100	factory adjusts Contrast	75
	W.COLOR	0~100	factory adjusts Color	0
	SC BRT	0~100	Subsidiary Bright Adjustment	50
	COOL	0~63	Cool color adjustment	8
	WARM	0~63	Warm color adjustment	8
M9	AV2	ON/OFF	AV2 selection	ON
	SVHS	ON/OFF	S-VIDEO selection	ON
	DVD	ON/OFF	DVD (Y U V) selection	ON
	EURO	ON/OFF	SCART selection	ON
	AUTO SOUND	ON/OFF	Auto sound system as auto search	ON
	BG	ON/OFF	Sound system of 6.0M selecting	ON
	I	ON/OFF	Sound system of 5.5M selecting	ON
	M	ON/OFF	Sound system of 4.5M selecting	ON
	DK	ON/OFF	Sound system of 6.5M selecting	ON
	SIF PRI	ON/OFF	Force sound system as auto search	ON
	POWER REST	0~3	AC power on start selection	1

	BANLANCE	ON/OFF	AV stereo selection (ON:AV STEREO OFF:MONO)	OFF
	HALFTONE	ON/OFF	Half tone select	OFF
	KEY OPT	SANYO/MEK	KEY BOARD selection	SANYO
	CURTAIN	0~2	CURTAIN selection	2
	LOGO	ON/OFF	Logo selection	OFF
	B . BACK	ON/OFF		ON
	TILT	ON/OFF	TILT selection	OFF
	ASM OPT	0~1	Search speed selection	1
	V.MUTE P.OFF	ON/0~7	Select whether cutoff RGB output from solution while power off	ON
	AV OUT		CVBS: AV output to follow the screen IF: AV output has always been to follow the TV	CVBS
	COMBO	USB/DVD/OFF	Extensions to choose	

KEY BOARD: multiple-choice test(0/1)

0: Control keys input (Max. Limit voltage) ---(MEK KEY BOARD)

Function	POWER	MENU	TV/AV	V-	V+	P-	P+
Voltage	0	0.4125	0.825	1.2375	1.65	2.0625	2.475

1: Control keys input (Max. Limit voltage) --(SANYO KEY BOARD)

Function	POWER	MENU	TV/AV	V-	V+	P-	P+
Voltage		2.2	1.75	0.85	1.3	0.4	0.0

4 , LOGO EDIT

This software LOGO is a pair of pleased words and customer to edit 2 kinds, at the M_MODE, long press[P.P]the key can get into a pair of pleased words editor appearance.

(Operate

Press[1]/[2] keys: The LOGO perpendicular position adjust, [1] adjusts upward, [2] get down adjustment;

Press[3]/[4] keys: The LOGO level position adjust, [3] is to the left adjustment, [4] rightwards adjusts;

Press[REVIEW]key: Withdraw LOGO editor appearance, the LOGO information remembers EEPROM and return to M_MODE;

Press again[MENU]the key can get into and can edit LOGO appearance.

(Operate

Press[1]/[2] keys: The LOGO perpendicular position adjust, [1] adjusts upward, [2] get down adjustment;

Press[3]/[4] keys: The LOGO level position adjust, [3] is to the left adjustment, [4] rightwards adjusts;
 Press[5]/[6] keys: The color choice of the LOGO character list, [5] regulate the first color, [6] regulate the second color;
 Press[7]/[8] keys: The LOGO character list size adjust, [7] regulate the first size, [8] regulate the second size;
 Press[0] keys:Delete the letter of alphabet of importation

Press[]/[]key: The LOGO character list choose(0~9;A~Z;a~z; ".: + * / @", SPACE);
 Press[]/[]key: Move cursor;
 Press[REVIEW]key: Withdraw LOGO editor appearance, the LOGO information remembers EEPROM and return to M_MODE;

5. The ZOOM adjust.

At the M_MODE, press[ZOOM]key: Press when screen showed "ZOOM" or"16:9"[VOL+]/[VOL-]the key regulated ZOOM/16:9 of field.

ICs functional description

UOC TDA11105-XXXX/TDA11106-XXXX

SYMBOL	PIN	DESCRIPTION
IF VO	1	IF video output / selected CVBS output
VP2	2	2 ND Supply voltage TV processor(+5v)
VCC AUDIO	3	8 volt supply for audio switches(+5V~8V)
PLL IF	4	IF-PLL loop filter
GND2	5	Gaound 2 for TV processor
DECSDEM	6	decoupling sound demodulator or SIF input 2
FMDEMOUT	7	audio output /AM audio output (volume controlled)
EHTO	8	EHT/overvoltage protection input
AGC	9	Tuner AGC output
IREF	10	Reference current input
VSC	11	Vertical sawtooth capacitor
IF IN2	12	IF input 1
IF IN1	13	IF input 2
VDRA	14	Vertical drive A output
VDRB	15	Vertical drive B output
AVL/EW	16	Automatic volume leveling /EAST-WEST drive output
DECBG	17	Band gap decoupling
SECPLL	18	SECAM PLL decoupling
GND1	19	Ground 1 for TV-processor
PH1LF	20	Phase-1 filter
PH2LF	21	Phase-2 filter
VP1	22	1 st supply voltage TV-processor(+5V)

DECDIG	23	decoupling digital supply of TV-processor
XTALOUT	24	crystal oscillator output
XTALIN	25	crystal oscillator input
IR	26	Remote control signal input.
MUTE	27	Sound mute output
TILT/UHF	28	
KEY	29	Control keys input *3
BAND2	30	Tuner Band selection output
BAND1	31	Tuner Band selection output
TUNING	32	tuning Voltage (Vt) PWM output
VDDP	33	Supply to periphery-3.3V)
SDA	34	I ² C-bus data line

SCL	35	I ² C-bus clock line
AV1	36	TV/AV (AV1) / AV2 mode Control Output.
AV2	37	TV/AV (AV1) / AV2 mode Control Output.
STANDBY	38	In STAND BY mode, high level (Power OFF).For Power ON this pin will be reduced to low.
50/60	39	
VDDC	40	Supply(3.3V)
GND5	41	Ground 5
VPE	42	OPT programming Voltage
VDDA	43	Supply voltage(3.3V)
BOUT	44	Blue output
GOUT	45	Green output
ROUT	46	Red output
BLKIN	47	black current input / V-guard input
BCL IN	48	beam current limiter input
PB	49	B input / U (B-Y) input / P _B input
Y3/CVBS3	50	G input / Y input
PR/C3	51	R input / V (R-Y) input / P _R input
YOUT	52	Y-output(for YUV interface)
Y SYNC	53	Y-input for sync separator
VP3	54	Supply voltage(5V)
GND3	55	Ground connection
HOUT	56	Horizontal output
FBISO	57	Flyback input/sandcastle output
LSR	58	Audio output R
LSL	59	Audio output L
C2/C3/C4/AIN5R	60	S-VIDEO C IN
AIN3/IN1R	61	R AUDIO IN
CVBS2/Y2	62	AV2 VIDEO IN

AIN2/1INL	63	L AUDIO IN
CVBS/Y4/AIN5L	64	AV1 VIDEO IN

AN7522/AN17821/AN7523/AN17823 Function : **audio output**

Symbol	PIN	Function	Symbol	PIN	Function
Vcc	1	Power supply	GND	7	ground
Out 1 (+)	2	Ch 1 output (+)	In 2	8	Ch 2 input
GND(out 1)	3	Ch 1Ground	VOL	9	Volume Control
Out 1 (-)	4	Ch 1 output (-)	Out 2 (-)	10	Ch 2 output (-)
Standby	5	Mute input	GND(out 2)	11	Ch 2 Ground
In 1	6	Ch 1 input	Out 2 (+)	12	Ch 2 output (+)

Note: AN7523 is pin 1 to 9, AN7522 is pin 1 to 12.

LA9302A/8177/LA78041/LA78040/STV9325/STV9378 Function : **vertical output**

Symbol	PIN	Function	Symbol	PIN	Function
INV IN	1	Input	V OUT	5	Vertical output
VCC1	2	Power	VCC2	6	Output power supply
PUMP UP	3	Pump up power	NON INV IN	7	Negative feedback
GND	4	Ground			

Test point Waveforms

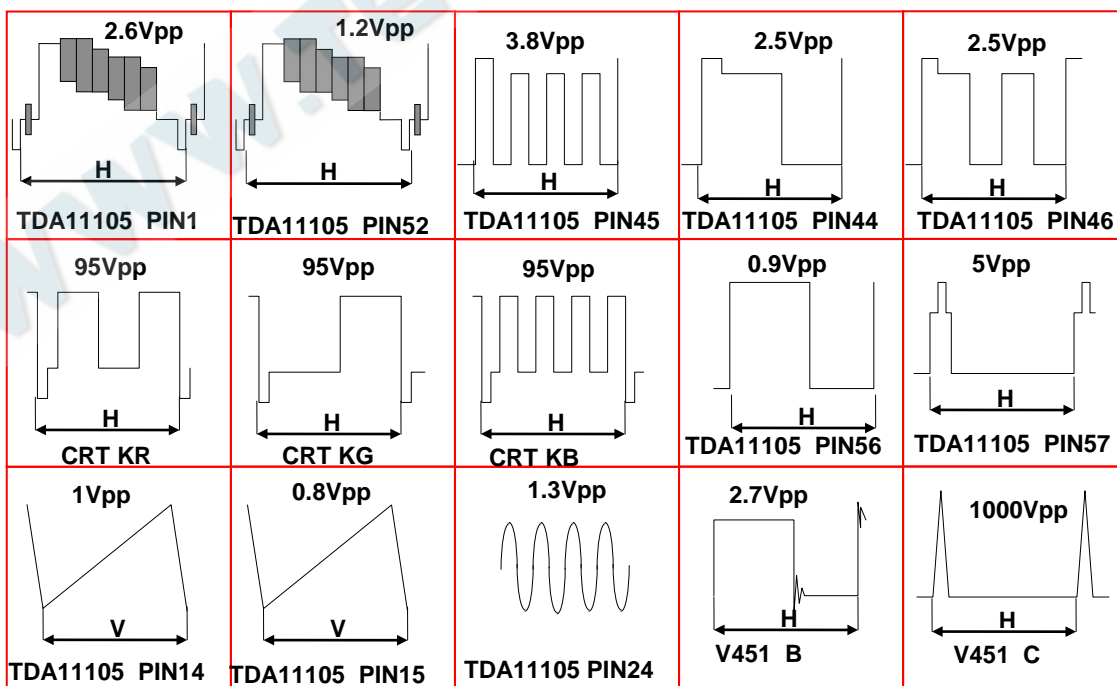

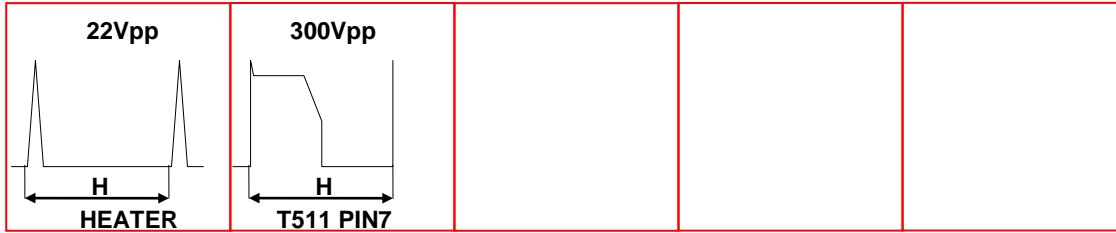

TDA8177 / STv9302/ LA78040 or LA78041/ STV9325/STV9378

PIN	1	2	3	4	5	6	7
V	0.7	15	-12	-15	0.3	15.9	-0.07

AN 7522/AN17821 (Note: AN7523 is pin 1 to 9, AN7522 is pin 1 to 12.)

PIN	1	2	3	4	5	6	7	8	9	10	11	12
V	12	7	0	7	3.3	1.4	0	1.4	0	7	0	7

PURITY / CONVERGENCE ADJUSTMENT

PURITY ADJUSTMENT

1. Demagnetize CRT with the demagnetizer.
2. Loosen the retainer screw of the deflection yoke.
3. Remove the wedges.
4. Input a green raster signal from the signal generator, and turn the screen to green raster.
5. Move the deflection yoke backward.
6. Bring the long lug of the purity magnets on the short lug and position them horizontally. (Fig2)
7. Adjust the gap between two lugs so that the GREEN RASTER will come into the center of the screen. (Fig. 3)
8. Move the deflection yoke forward, and fix the position of the deflection yoke so that the whole screen will become green.
9. Insert the wedge to the top side of the deflection yoke so that it will not move.
10. Input a crosshatch signal.
11. Verify that the screen is horizontal.
12. Input red and blue raster signals, and make sure that purity is properly adjusted.

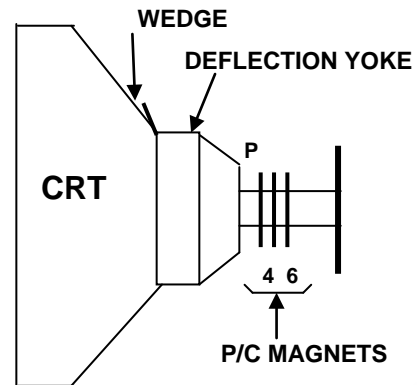

P: PURITY MAGNET
 4: 4-POLES (convergence magnets)
 6: 6-POLES (convergence magnets)

Fig. 1

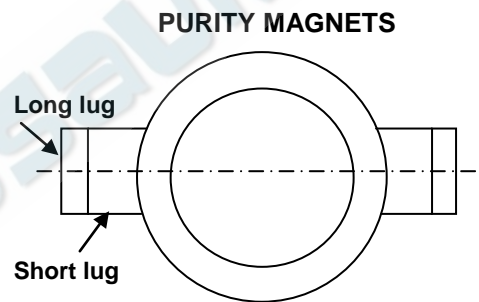

Bring the long lug over the short lug and position them horizontally.

Fig. 2

(FRONT VIEW)

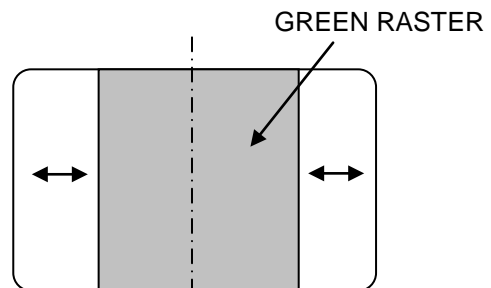
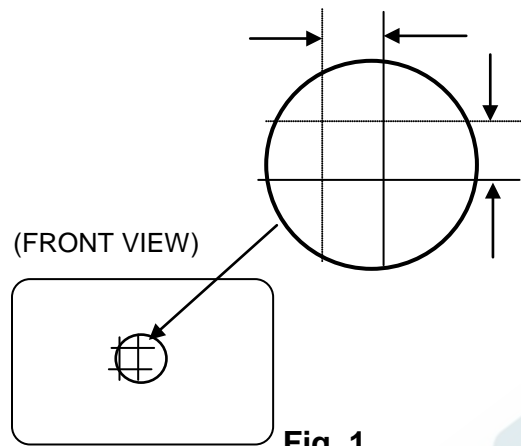

Fig. 3

STATIC CONVERGENCE ADJUSTMENT

1. Input a crosshatch signal.
2. Using 4-pole convergence magnets, overlap the red and blue lines in the center of the screen (Fig. 1) and turn them to magenta (red/blue).
3. Using 6-pole convergence magnets, overlap the magenta (red/blue) and green lines in the center of the screen and turn them to white.
4. Repeat 2 and 3 above, and make the best convergence.



DYNAMIC CONVERGENCE ADJUSTMENT

1. Move the deflection yoke up and down and overlap lines in the periphery. (Fig. 2)
2. Move the deflection yoke left to right and overlap the lines in the periphery. (Fig. 3)
3. Repeat 1 and 2 above, and make the best convergence.

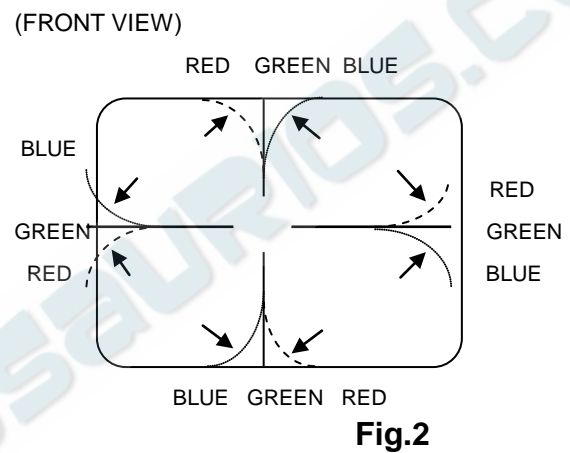

After adjustment, fix the wedge at the original position.
Fasten the retainer screw of the deflection yoke.
Fix the 6 magnets with glue.

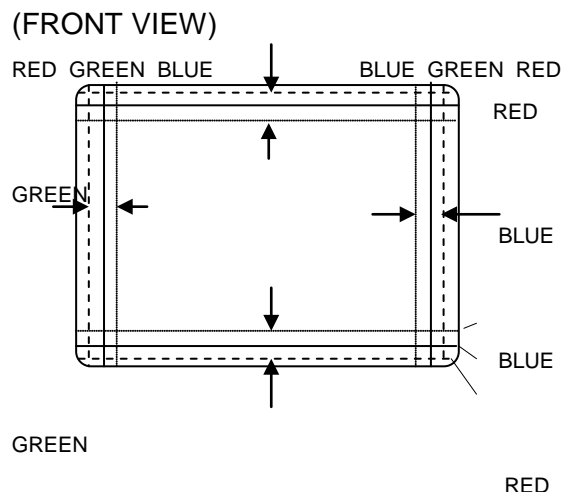

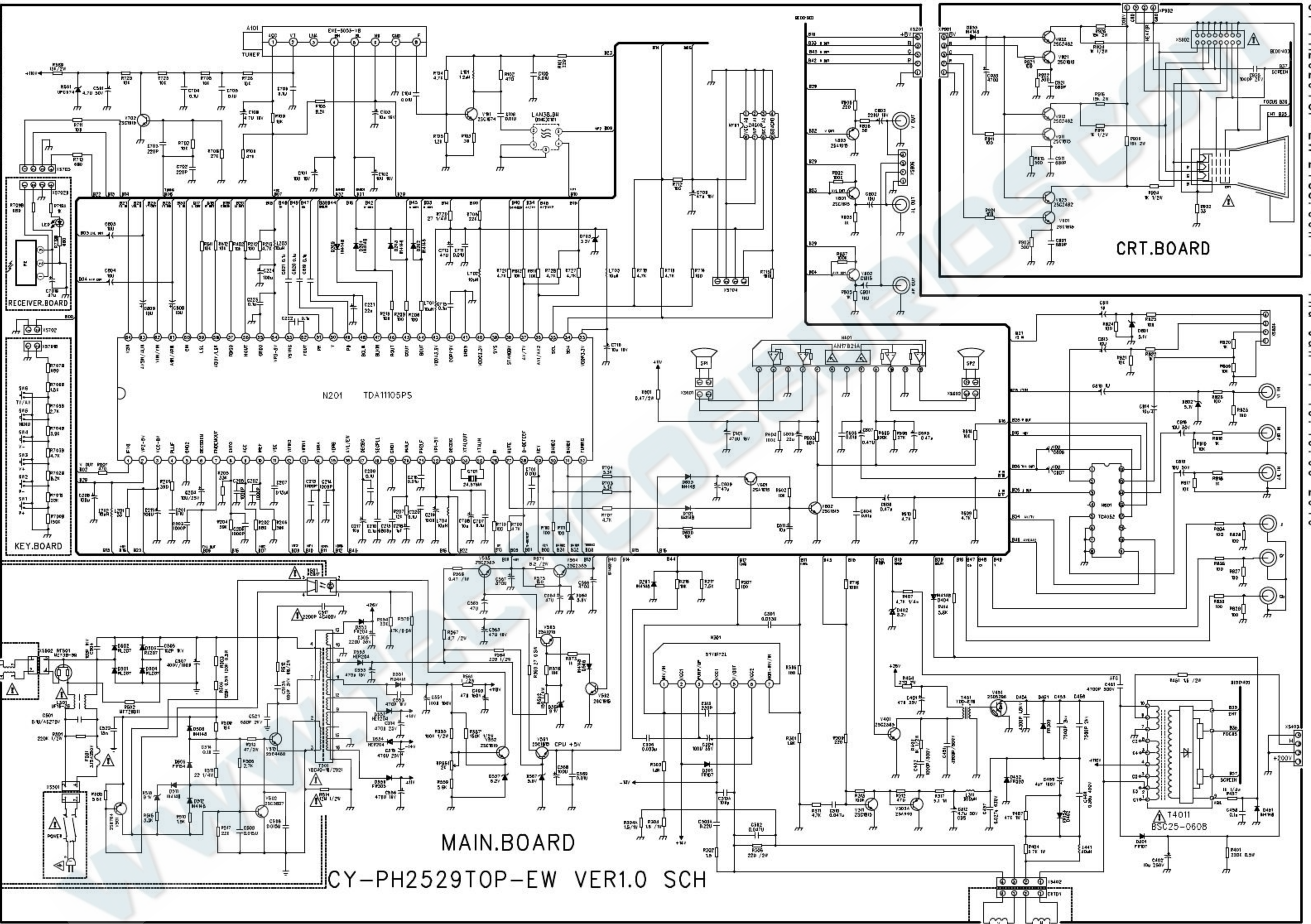

PDF 文件使用 "pdf" 阅读器

MAIN BOARD

CY-PH2529TOP-EW VER1.0 SCH

2127US/2128US Main BOM 2010-05-21

NO.	PART NO.	NAME	SPECIFICATION	DESCRIPTION	UNIT	QUA NTI	PART PLACE	BOARD PLACE
1	28-PCBPH00-210	MAIN PCB	CY-PH 2 5 2 9 TOP		PCS	1		
2	10-0024C08-000	IC	AT24C08		PCS	1	N701	MAIN
3	10-0011105-000	IC	NT11136PC305EG		PCS	1	N201	MAIN
4	10-0000574-P05	IC	UPC574/KA33V	BELT	PCS	1	N561	MAIN
5	10-0004052-000	IC	TC4052/HCF4052BE		PCS	1	N801	MAIN
6	10-0078041-000	IC	LA78141/STV8172L		PCS	1	N301	MAIN
7	10-0000817-000	IC	PC817B/LTV-817/EL817		PCS	1	N501	MAIN
8	10-0017821-000	IC	AN17821A/AN7522		PCS	1	N601	MAIN
9	11-2SC3807-P00	TRANSISTOR	2SC3807		PCS	1	V502	MAIN
10	11-2SC5296-P00	TRANSISTOR	D5036/2SC5296		PCS	1	V451	MAIN
11	11-2SC5299-P00	TRANSISTOR	2SC4460		PCS	1	V513	MAIN
12	11-2SC2383-P05	TRANSISTOR	2SC2383	BELT	PCS	3	V401, V564, V565	MAIN
13	11-02SB764-P05	TRANSISTOR	2SB764	BELT	PCS	1	V501	MAIN
14	11-2SC1815-P05	TRANSISTOR	2SC1815-Y	BELT	PCS	8	V552, V561, V562, V602, V702, V801, V802, V311	MAIN
15	11-2SA1015-P05	TRANSISTOR	2SA1015-Y	BELT	PCS	3	V563, V601, V803	MAIN
16	11-2SC1674-P05	TRANSISTOR	2SC1674	BELT	PCS	1	V101	MAIN
18	11-2SD2012-P00	TRANSISTOR	A940		PCS	1	V303A	MAIN
19	12-0IN4148-P52	SWITCHING DIODE	IN4148	BELT	PCS	10	D201, D205, D404, D461, D508, D511, D512, D566, D701, D603	MAIN
20	12-00RL207-P52	SWITCHING DIODE	IN5399/RL207	BELT	PCS	4	D501, D502, D503, D504	MAIN
21	12-00FR107-P52	SWITCHING DIODE	FR107/FR157	BELT	PCS	2	D301, D401	MAIN
22	12-00FR154-P52	SWITCHING DIODE	FR154	BELT	PCS	2	D506, D462	MAIN
23	12-00FR204-125	SWITCHING DIODE	FR204	12.5mm	PCS	1	D553	MAIN
24	12-00FR305-125	SWITCHING DIODE	FR305	12.5mm	PCS	2	D556, D452	MAIN
25	12-00FR309-125	SWITCHING DIODE	FR309	12.5mm	PCS	1	D451	MAIN
26	12-0HER204-125	SWITCHING DIODE	HER204	12.5mm	PCS	3	D552, D554, D555	MAIN
27	12-0HER308-125	SWITCHING DIODE	RU4AM	12.5mm	PCS	1	D551	MAIN
28	12-03C23V3-P52	ZENER DIODE	3.3V/3C2	BELT	PCS	1	D703	MAIN
29	12-05C25V1-P52	ZENER DIODE	5.1V/5C2	BELT	PCS	2	D801, D802	MAIN

30	12-06A25V6-P52	ZENER DIODE	5.6V/6A2/6B1	BELT	PCS	2	D567, D564	MAIN
31	12-06C36V3-P52	ZENER DIODE	6.2V/6C3	BELT	PCS	1	D557	MAIN
32	12-07C27V5-P52	ZENER DIODE	9C1/9.1V	BELT	PCS	1	D515	MAIN
33	12-09A28V2-P52	ZENER DIODE	8.2V/9A2	BELT	PCS	4	D402, D202, D203, D204	MAIN
34	12-09B29V1-P52	ZENER DIODE	9.1V/9C2	BELT	PCS	1	D561	MAIN
35	16-RTF330J-P52	CARBON FILM RESISTOR	RT-1/6W-33Ω-J	26mm BELT	PCS	1	L201	MAIN
36	16-RTF390J-P52	CARBON FILM RESISTOR	RT-1/6W-39Ω-J	26mm BELT	PCS	1	R103	MAIN
37	16-RTF560J-P52	CARBON FILM RESISTOR	RT-1/6W-56Ω-J	26mm BELT	PCS	1	R838	MAIN
38	16-RTF101J-P52	CARBON FILM RESISTOR	RT-1/6W-100Ω-J	26mm BELT	PCS	17	R110, R111, R208, R209, R210, R212, R306, R307, R710, R711, R712, R714, R715, R824, R825, R826, R832	MAIN
39	16-RTF221J-P52	CARBON FILM RESISTOR	RT-1/6W-220Ω-J	26mm BELT	PCS	3	R101, R806, R309	MAIN
41	16-RTF391J-P52	CARBON FILM RESISTOR	RT-1/6W-390Ω-J	26mm BELT	PCS	1	R201	MAIN
42	16-RTF471J-P52	CARBON FILM RESISTOR	RT-1/6W-470Ω-J	26mm BELT	PCS	3	R102, R807, R312	MAIN
43	16-RTF681J-P52	CARBON FILM RESISTOR	RT-1/6W-680Ω-J	26mm BELT	PCS	2	R202, R713	MAIN
44	16-RTF102J-P52	CARBON FILM RESISTOR	RT-1/6W-1KΩ-J	26mm BELT	PCS	8	R573, R803, R805, R816, R818, R820, R822, R704	MAIN
45	16-RTF122J-P52	CARBON FILM RESISTOR	RT-1/6W-1.2KΩ-J	26mm BELT	PCS	1	R105	MAIN
46	16-RTF182J-P52	CARBON FILM RESISTOR	RT-1/6W-1.8KΩ-J	26mm BELT	PCS	2	R301, R303	MAIN
47	16-RTF242J-P52	CARBON FILM RESISTOR	RT-1/6W-1.5KΩ-J	26mm BELT	PCS	1	R510	MAIN
48	16-RTF272J-P52	CARBON FILM RESISTOR	RT-1/6W-2.7KΩ-J	26mm BELT	PCS	1	R506	MAIN
49	16-RTF332J-P52	CARBON FILM RESISTOR	RT-1/6W-3.3KΩ-J	26mm BELT	PCS	3	R516, R703, R704	MAIN
50	16-RTF472J-P52	CARBON FILM RESISTOR	RT-1/6W-4.7KΩ-J	26mm BELT	PCS	12	R104, R213, R609, R610, R707, R709, R718, R719, R721, R727, R728, R311	MAIN
51	16-RTF562J-P52	CARBON FILM RESISTOR	RT-1/6W-5.6KΩ-J	26mm BELT	PCS	2	R505, R559	MAIN
52	16-RTF752J-P52	CARBON FILM RESISTOR	RT-1/6W-7.5KΩ-J	26mm BELT	PCS	1	R217	MAIN
53	16-RTF822J-P52	CARBON FILM RESISTOR	RT-1/6W-8.2KΩ-J	26mm BELT	PCS	1	R108	MAIN
54	16-RTF103J-P52	CARBON FILM RESISTOR	RT-1/6W-10KΩ-J	26mm BELT	PCS	20	R109, R402, R576, R602, R611, R612, R614, R702, R705, R723, R725, R726, R811, R812, R815, R817, R821, R836, R216, D600	MAIN
55	16-RTF123J-P52	CARBON FILM RESISTOR	RT-1/6W-12KΩ-J	26mm BELT	PCS	1	R207	MAIN
56	16-RTF153J-P52	CARBON FILM RESISTOR	RT-1/6W-15KΩ-J	26mm BELT	PCS	1	R509	MAIN

57	16-RTF223J-P52	CARBON FILM RESISTOR	RT-1/6W-22KΩ-J	26mm BELT	PCS	3	R517, R706, R554	MAIN
58	16-RTF273J-P52	CARBON FILM RESISTOR	RT-1/6W-27KΩ-J	26mm BELT	PCS	2	R708, R606	MAIN
59	16-RTF393J-P52	CARBON FILM RESISTOR	RT-1/6W-39KΩ-J	26mm BELT	PCS	1	R206	MAIN
60	16-RTF473J-P52	CARBON FILM RESISTOR	RT-1/6W-47KΩ-J	26mm BELT	PCS	1	R106	MAIN
61	16-RTF683J-P52	CARBON FILM RESISTOR	RT-1/6W-68KΩ-J	26mm BELT	PCS	1	R603	MAIN
62	16-RTF104J-P52	CARBON FILM RESISTOR	RT-1/6W-100KΩ-J	26mm BELT	PCS	6	R604, R802, R837, R313, R605, R716	MAIN
63	16-RTG10AJ-P52	CARBON FILM RESISTOR	RT-1/4W-1Ω-J	26mm BELT	PCS	1	R302	MAIN
64	16-RTG220J-P52	CARBON FILM RESISTOR	RT-1/4W-22Ω-J	26mm BELT	PCS	1	R511	MAIN
65	16-RTG270J-P52	CARBON FILM RESISTOR	RT-1/4W-27Ω-J	26mm BELT	PCS	1	R720	MAIN
67	16-RTG151J-P52	CARBON FILM RESISTOR	RT-1/4W-150Ω-J	26mm BELT	PCS	2	R575, R562	MAIN
68	16-RTG102J-P52	CARBON FILM RESISTOR	RT-1/4W-1KΩ-J	26mm BELT	PCS	1	R457	MAIN
69	16-RTG472J-P52	CARBON FILM RESISTOR	RT-1/4W-4.7KΩ-J	26mm BELT	PCS	1	R407	MAIN
70	16-RTG224J-P52	CARBON FILM RESISTOR	RT-1/4W-220KΩ-J	26mm BELT	PCS	1	R401	MAIN
71	16-RTH221J-P52	CARBON FILM RESISTOR	RT-1/2W-220Ω-J	BELT	PCS	1	R564	MAIN
72	16-RTH102J-P52	CARBON FILM RESISTOR	RT-1/2W-1KΩ-J	BELT	PCS	1	R403	MAIN
73	16-RTH223J-P52	CARBON FILM RESISTOR	RY-1W-47KΩ-J(FORMING)	BELT	PCS	1	R487	MAIN
74	16-RIH126K-P52	HIGH VOLTAGE INSULATED RESIS.	RI40-1/2W-12MΩ-K	BELT	PCS	1	R514	MAIN
75	16-RYH27AJ-P52	METAL OXIDE FILM RESISTOR	RY-1/2W-22Ω-J	BELT	PCS	1	R560	MAIN
76	16-RYH104J-P52	METAL OXIDE FILM RESISTOR	RY-1/2W-100KΩ-J	BELT	PCS	1	R555	MAIN
77	16-RYH124J-P52	METAL OXIDE FILM RESISTOR	RY-1/2W-120KΩ-J	BELT	PCS	2	R503, R504	MAIN
78	16-RYH154J-P52	METAL OXIDE FILM RESISTOR	RY-1/2W-150KΩ-J	BELT	PCS	1	R557	MAIN
79	16-RYI047J-L15	METAL OXIDE FILM RESISTOR	RY-1W-0.47Ω-J	15mm	PCS	1	R568	MAIN
80	16-RYI51AJ-L15	METAL OXIDE FILM RESISTOR	RY-1W-5.1Ω-J	15mm	PCS	1	R317	MAIN
81	16-RYI473J-L15	METAL OXIDE FILM RESISTOR	RY-1/2W-47KΩ-J	15mm	PCS	1	R570	MAIN
82	16-RYJ047J-L20	METAL OXIDE FILM RESISTOR	RY-2W-0.47Ω-J	20mm	PCS	1	R601	MAIN
83	16-RYJ10AJ-L20	METAL OXIDE FILM RESISTOR	RY-2W-1Ω-J	20mm	PCS	1	R561	MAIN
84	16-RYJ47AJ-L20	METAL OXIDE FILM RESISTOR	RY-2W-4.7Ω-J	20mm	PCS	1	R567	MAIN
85	16-RYJ82AJ-L20	METAL OXIDE FILM RESISTOR	RY-2W-8.2Ω-J	20mm	PCS	1	R571	MAIN
86	16-RYJ680J-L20	METAL OXIDE FILM RESISTOR	RY-2W-68Ω-J	20mm	PCS	1	R512	MAIN
87	16-RYJ271J-L20	METAL OXIDE FILM RESISTOR	RY-2W-270Ω-J	20mm	PCS	1	R454	MAIN
88	16-RYJ153J-L20	METAL OXIDE FILM RESISTOR	RY-2W-15KΩ-J	20mm	PCS	1	R569	MAIN
89	16-RX533AJ-000	ORGANIC SOLID RESISTOR	RY-2W-47Ω-J		PCS	1	R513	MAIN

90	16-MF7211J-000	THERMISTOR THERMISTOR	MF72-8D11		PCS	1	R502	MAIN
91	16-RM739AJ-000	DEGAUSSING THERMISTOR	MZ73B-9Ω (3pin)		PCS	1	RT501	MAIN
92	16-RW02K2J-000	TRIMMER POTENTIOMETER	W206-2AL2KΩ-K		PCS	1	RP551	MAIN
93	17-2FJ221J-P05	CERAMIC CAPACITOR	CT1-RH-63V-220pF-J	BELT	PCS	3	C313、C702、C703	MAIN
95	17-2FJ102J-P05	CERAMIC CAPACITOR	CT1-2B-63V-1000pF-J	BELT	PCS	5	C202、C203、C205、C213、C214	MAIN
96	17-2FJ103Z-P05	CERAMIC CAPACITOR	CT1-2F-63V-0.01μF-Z	BELT	PCS	9	C104、C105、C106、C216、C569、C604、C606、C701、C711	MAIN
97	17-2FJ104J-P05	CERAMIC CAPACITOR	CT1-2F-63V-0.1μF-K	BELT	PCS	5	C220、C222、C223、C707、C713	MAIN
98	17-2BR102K-P05	CERAMIC CAPACITOR	CT81-2B-500V-1000pF-K	BELT	PCS	1	C452	MAIN
99	17-2BR392K-P05	CERAMIC CAPACITOR	CT81-2B-500V-3900pF-K	BELT	PCS	1	C451	MAIN
100	17-2BR472K-P05	CERAMIC CAPACITOR	CT81-2B-500V-4700pF-K	BELT	PCS	1	C461	MAIN
101	17-2BT102K-L10	CERAMIC CAPACITOR	CT81-2B-1KV-1000pF-K		PCS	3	C504、C505、C562	MAIN
102	17-2BT471K-7L5	CERAMIC CAPACITOR	CT81-2B-1KV-470pF-K		PCS	1	C553	MAIN
103	17-2BV681K-7L5	CERAMIC CAPACITOR	CT81-2B-2KV-680pF-K		PCS	2	C513A、C521	MAIN
105	17-ACP222M-L10	CERAMIC CAPACITOR	CT7-2E4-400VAC-2200pF-M		PCS	1	C517	MAIN
106	17-00K472K-P05	INDUCTVE POLY.CAPACITOR	CL11-100V-0.015μF-J	BELT	PCS	1	C522	MAIN
107	17-00K682K-P05	INDUCTVE POLY.CAPACITOR	CL11-100V-6800pF-J	BELT	PCS	1	C215	MAIN
108	17-00K153K-P05	INDUCTVE POLY.CAPACITOR	CL11-100V-0.015μF-J	BELT	PCS	1	C508	MAIN
109	17-00K333K-P05	INDUCTVE POLY.CAPACITOR	CL11-100V-0.033μF-J	BELT	PCS	2	C301、C306	MAIN
110	17-00K473K-P05	INDUCTVE POLY.CAPACITOR	CL11-100V-0.047μF-J	BELT	PCS	2	C302、C310	MAIN
111	17-00K104K-P05	INDUCTVE POLY.CAPACITOR	CL11-100V-0.1μF-J	BELT	PCS	8	C201、C209、C303、C458、C514、C704、C705、C706	MAIN
112	17-22S153K-P05	METALIZED POLY.CAPACITOR	CL21X-100V-0.015μF-J	BELT	PCS	1	C509	MAIN
113	17-22S104K-P05	METALIZED POLY.CAPACITOR	CL21X-100V-0.15μF-J	BELT	PCS	1	C207	MAIN
114	17-0AN104M-L15	METALIZED POLY.CAPACITOR	CBB23A-275VAC-0.1μF-M/CIS-250AC-0.1μF-M		PCS	1	C501	MAIN
115	17-00E47AM-P05	MINI ELEC.CAPACITOR	CD110-16V-4.7μF-M	BELT	PCS	1	C108	MAIN
116	17-00E100M-P05	MINI ELEC.CAPACITOR	CD110-16V-10μF-M	BELT	PCS	18	C101、C102、C103、C217、C708、C710、C801、C802、C804、C805、C806、C807、C808、C809、C813、C814、C815、C816	MAIN
117	17-00E220M-P05	MINI ELEC.CAPACITOR	CD110-16V-22μF-M	BELT	PCS	2	C221、C605	MAIN
118	17-00E470M-P05	MINI ELEC.CAPACITOR	CD110-16V-47μF-M	BELT	PCS	6	C563、C564、C565、C709、C712、C609	MAIN
119	17-00E101M-P05	MINI ELEC.CAPACITOR	CD110-16V-100μF-M	BELT	PCS	5	C208、C211、C219、C224、C568	MAIN

120	17-00E221M-P05	MINI ELEC.CAPACITOR	CD110-16V-220μF-M	BELT	PCS	1	C803	MAIN
121	17-00E471M-P05	MINI ELEC.CAPACITOR	CD110-16V-470μF-M	BELT	PCS	3	C566、C567、C601	MAIN
122	17-00F100M-P00	MINI ELEC.CAPACITOR	CD110-25V-10μF-M	BELT	PCS	1	C204	MAIN
123	17-00H471M-P00	MINI ELEC.CAPACITOR	CD288H -16V-470μF	BELT	PCS	2	C555、C556	MAIN
124	17-00F471M-P00	MINI ELEC.CAPACITOR	CD288H -25V-470μF		PCS	2	C314、C315	MAIN
125	17-00G470M-P05	MINI ELEC.CAPACITOR	CD110-35V-47μF-M	BELT	PCS	1	C401	MAIN
126	17-00G101M-P05	MINI ELEC.CAPACITOR	CD288H-35V-100μF	BELT	PCS	1	C304	MAIN
127	17-00G221M-P00	MINI ELEC.CAPACITOR	CD288H-35V-220μF		PCS	1	C305	MAIN
128	17-00I047M-P05	MINI ELEC.CAPACITOR	CD110-50V-0.47μF-M	BELT	PCS	3	C603、C607、C608	MAIN
129	17-00I10AM-P05	MINI ELEC.CAPACITOR	CD110-50V-1μF-M	BELT	PCS	3	C218、C810、C811	MAIN
130	17-00I47AM-P05	MINI ELEC.CAPACITOR	CD110-50V-4.7μF-M	BELT	PCS	1	C561	MAIN
131	17-00M470M-PO0	MINI ELEC.CAPACITOR	CD288H-160V-47μF-M	BELT	PCS	1	C403	MAIN
132	17-00M101M-PO0	MINI ELEC.CAPACITOR	CD288H-160V-100μF-M		PCS	1	C551	MAIN
133	17-00M47AM-PO0	MINI ELEC.CAPACITOR	CD288H-160V-4.7μF-M		PCS	1	C459	MAIN
134	17-00Q100M-PO0	MINI ELEC.CAPACITOR	CD288H-250V-10μF-M		PCS	1	C402	MAIN
135	17-00P221M-000	MINI ELEC.CAPACITOR	CD293-400V-100μF-M		PCS	1	C507	MAIN
136	17-00I100M-P00	MINI ELEC.CAPACITOR	CDS -50V-4.7μF		PCS	1	C312	MAIN
137	19-30712AK-P52	INDUCTOR WITH COLOR	LG0307-1.2μH-K	BELT	PCS	1	L101	MAIN
138	19-307100K-P52	INDUCTOR WITH COLOR CIDES	LG0307-10μH-K	BELT	PCS	6	L202、L203、L701、L702、L703、L704	MAIN
139	20-1826600-000	HORIZONTAL LINEARITY COIL	JLC/YDD-600μH		PCS	1	L311	MAIN
140	24-2456700-000	QUARTZ	X24.576M		PCS	1	G701	MAIN
141	23-EVE5053-000	TUNER	DWE-5053-V8		PCS	1	A101	MAIN
142	20-BCK1899-000	SWITCHING POWER TRANSFORMER	YBC40-19/2921		PCS	1	T501	MAIN
143	20-0UUE119-000	HORIZONTAL DRIVE TRANSFORMER	JBC-184-EI19/YDD-EI19		PCS	1	T451	MAIN
144	20-000ET24-000	FPOWER FILTER TRANSFORMER	YDD-UF16		PCS	1	L501	MAIN
145	24-0KDV380-000	IF FILTER	F38.0H/LBN38.0H		PCS	1	Z101	MAIN
146	25-00BXGJ1-000	FUSE BRACKET	BXGJ-1		PCS	2	FU501	MAIN
147	25-250V315-000	FUSE	T3.15A250V-AC		PCS	1	FU501	MAIN
149	25-H7100D2-000	ERTH CONNECTOR	CH7-10-2DY		PCS	2	XS501、XS502	MAIN
150	25-CH655D0-000	ERTH CONNECTOR	CH6-5-5DY (少一針)		PCS	1	XS402	MAIN

151	25-5B025D2-000	ERTH CONNECTOR	CH5B-2.5-2DY		PCS	3	XS601、XS602、XS702	MAIN
152	25-5B025D4-000	ERTH CONNECTOR	CH5B-2.5-4DY		PCS	3	XS703、XS704、XS804、XS403	MAIN
153	25-5B025D5-000	ERTH CONNECTOR	CH5B-2.5-5DY		PCS	1	XS201	MAIN
156	25-00AV614-000	6AV TIP JACK	AV6-14		PCS	1	XS801	MAIN
157	32-00H3410-000	HEAT SINK(IC.VERTICAL)	H3410C		PCS	1	N301、V451	MAIN
158	32-00D2534-000	HEAT SINK(POWER)	D1421		PCS	1	V513	MAIN
159	32-00Z2534-000	HEAT SINK	Z2534		PCS	1	V303A	MAIN
160	32-017821M-000	HEAT SINK(AUDIO)	17821M		PCS	1	N601	MAIN
161	43-1102030-000	RIVET	2.0 X 3.0MM		PCS	2	L441	MAIN
162	43-1103082-000	SCREW FOR HEAT SINK	M 3×8		PCS	3	N301、N601(2)	MAIN
163	43-1103102-000	SCREW FOR HEAT SINK	M 3×10		PCS	2	V513、V451	MAIN
164	43-1103102-000	SCREW FOR HEAT SINK	TR 3×10		PCS	1	V303A	MAIN
165	43-7130000-000	NUT FOR HEAT SINK	M3		PCS	5	N301、V451、V513、N601(2)	MAIN
166		JUMPER	5mm		PCS	3	W608、W718、W312	MAIN
167		JUMPER	7.5mm		PCS	30	W101、W201、W202、W207、W208、W209、W210、W212、W503、W508、W511、W552、W708、W710、W713、W801、W213、W606、R205、W214、W216、W512、W513、W807、W206、W203、W314、R319、R322、	MAIN
168		JUMPER	10mm		PCS	23	W404、W505、W506、W509、W510、W563、W591、W605、W701、W702、W704、W712、W802、W803、W804、W805、W806、W301、W302、W590、W553、W211、W310	MAIN
169		JUMPER	12.5mm		PCS	9	W502、W205、W204、W551、W561、W593、W709、W714、L403	MAIN
170		JUMPER	15mm		PCS	2	L301、W717	MAIN

CRT PARAMETER

21US THOMSON A51EMW032X0A1

NO.	PART NO.	SPECIFICATION	NAME	DESCRIPTION	UNIT	QUANTITY	PART PLACE	BOARD PLACE
1	16-RTF472J-P52	CARBON FILM RESISTOR	RT-1/6W-5.1KΩ-J	26mm BELT	PCS	1	R414	MAIN
2	16-RYI10AJ-L15	METAL OXIDE FILM RESISTOR	RY-1W-1.5Ω-J	15mm	PCS	2	R304、R304A	MAIN
3	16-RYI181J-L15	METAL OXIDE FILM RESISTOR	RY-1W-330Ω-J	15mm	PCS	1	R305	MAIN

4	16-RY1102J-L15	METAL OXIDE FILM RESISTOR	RY-1W-2.7KΩ-J	15mm	PCS	1	R404	MAIN
5	16-RFJ33AJ-L20	METAL OXIDE FILM RESISTOR	RF10-2W-1.5Ω-J	20mm	PCS	1	R451	MAIN
6	20-JL12830-000	HORIZONTAL LINEARITY COIL	40μH(大体积)		PCS	1	L441	MAIN
7	17-22P364K-L15	METALIZED POLY.CAPACITOR	CBB21-250V-0.36μF-J		PCS	1	C460	MAIN
8	17-22P333K-L15	METALIZED POLY.CAPACITOR	CBB21-630V-0.033μF-J		PCS	1	C457	MAIN
9	17-81U222J-L20	METALIZED POLY.CAPACITOR	CBB81-1.6KV-3300pF-J		PCS	1	C454	MAIN
10	17-81U622J-L20	METALIZED POLY.CAPACITOR	CBB81-1.6KV-6200PF-J		PCS	1	C455	MAIN
11	17-81U752J-L20	METALIZED POLY.CAPACITOR	CBB81-1.6KV-9100PF-J		PCS	1	C456	MAIN
12	18-0N0122Z-000	FLYBACK TRANSFORMER	BSC25-N0608		PCS	1	T401	MAIN
13	25-H7100D1-000	ERTH CONNECTOR	CH6-5-1DY		PCS	1	FBT NO.2	MAIN
15	NOTE:+B voltage 110V,deflection wire connect with 1st pin of FBT (Deflection wire use small pin)							

21"S/US CRT BOM 2010-05-21

NO.	PART NO.	NAME	SPECIFICATION	DESCRIPTION	UNIT	QUA NTI	TOTAL AMOUNT	PART PLACE
1		JUMPER	7.5mm		PCS	1	W901	CRT
2	28-PCBPH00-210	MAIN PCB	CY-PH 2 5 2 9 TOP(CRT)		PCS	1		
3	12-0IN4148-P52	SWITCHING DIODE	IN4148	BELT	PCS	1	D933	CRT
4	11-2SC1815-P05	TRANSISTOR	2SC1815-Y	BELT	PCS	3	V901、 V911、 V921	CRT
5	11-2SC2482-P05	TRANSISTOR	2SC2482	BELT	PCS	3	V912、 V922、 V923	CRT
6	16-RTF101J-P52	CARBON FILM RESISTOR	RT-1/6W-100Ω-J	BELT	PCS	3	R901、 R911、 R921	CRT
7	16-RTF301J-P52	CARBON FILM RESISTOR	RT-1/6W-300Ω-J	BELT	PCS	3	R903、 R913、 R922	CRT
8	16-RTG330J-P52	CARBON FILM RESISTOR	RT-1/4W-33Ω-J	BELT	PCS	1	R932	CRT
9	16-RTH102J-P52	CARBON FILM RESISTOR	RT-1/2W-1KΩ-J	BELT	PCS	3	R904、 R914、 R924	CRT
10	16-RYJ153J-L20	METAL OXIDE FILM RESISTOR	RY-2W-15KΩ-J	20mm	PCS	3	R906、 R916、 R926	CRT
11	17-2FJ681J-P05	CERAMIC CAPACITOR	CT1-2B4-63V-680pF-J	BELT	PCS	3	C901、 C911、 C921	CRT
12	17-2BV102K-7L5	CERAMIC CAPACITOR	CT81-2B-2KV-1000pF-K		PCS	1	C935	CRT
13	17-00E470M-P05	MINI ELEC.CAPACITOR	CD110-16V-47μF-M	BELT	PCS	1	C932A	CRT
14	25-H7100D1-000	ERTH CONNECTOR	CH7-10-1DY		PCS	1	KN9	CRT
15	26-94DY450-000	4PIN CONNECTOR	CH9-2.5-4DY-450-CH5B		PCS	1	XP902	CRT
16	26-95DY500-000	5PIN CONNECTOR	CH9-2.5-5DY-500-CH5B		PCS	1	XP901	CRT
17	25-GZS2108-000	CRT SOCKET	GZS10-2-108		PCS	1	XS902	CRT