

aiwa

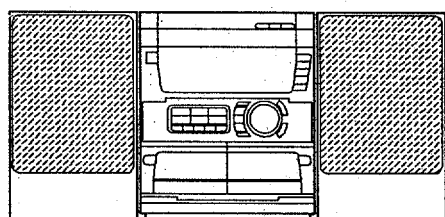

NSX-S70 NSX-S74



COMPACT DISC STEREO
CASSETTE RECEIVER

- BASIC TAPE MECHANISM : 2ZM-3MK2 PR4NM
- BASIC CD MECHANISM : 4ZG-1 Z1DNM
- TYPE : 70(EZ, K, V), 74HR

SYSTEM	CD CASSEIVER	SPEAKER	REMOTE CONTROLLER
NSX-S70	CX-NS70 (TYPE : EZ, K,V)	SX-ANS70	RC - 7AS08
NSX-S74	CX-NS74 (TYPE : HR)	SX-NS74 SX-R240	

- If requiring information about the CD mechanism, see Service Manual of 4ZG-1, S/M Code No. 09-974-187-50T.

MANUAL
SERVICE

SPECIFICATIONS

<FM Tuner section>

Tuning range	70EZ,K,74HR: 87.5 MHz to 108 MHz 70V: FM1: 65.0 MHz to 74.0 MHz FM2: 87.5 MHz to 108.0 MHz
Usable sensitivity(IHF)	74HR : 15.8 dBf 70EZ,K : 16.8 dBf 70V: FM1:15.3 dBf FM2:12.8 dBf
Antenna terminals	75 ohms (unbalanced)

<MW Tuner section>

Tuning range	531 kHz to 1602 kHz (9 kHz step) 530 kHz to 1710 kHz (10 kHz step)
Usable sensitivity	350 uV/m
Antenna	Loop antenna

<LW Tuner section> (70EZ,K,V)

Tuning range	144 kHz to 290 kHz
Usable sensitivity	1400 uV/m
Antenna	Loop antenna

<SW Tuner section> (74HR)

Tuning range	5.900 MHz to 17.900 MHz
Antenna	Wire antenna

<Amplifier section>

Power output	74HR : Rated 120 W + 120 W (6 ohms, T.H.D.1%, 1 kHz) 70EZ,K,V : Rated 100 W + 100 W (6 ohms, T.H.D.1%, 1 kHz/DIN 45500) Reference: 125 W + 125 W (6 ohms, T.H.D.10%, 1 kHz/DIN 45324) DIN MUSIC POWER 230 W + 230 W
---------------------	--

*without connecting to the SURROUND SPEAKERS

Total harmonic distortion	74HR : 0.05% (110 W, 1 kHz, 6 ohms, DIN AUDIO) 70EZ,K,V : 0.05% (90 W, 1 kHz, 6 ohms, DIN AUDIO)
Inputs	VIDEO/AUX : 210 mV(adjustable) MD : 210mV (adjustable) MIC 1,MIC 2: 1.4mV (10 kohms)
Outputs	LINE OUT: 200mV 74HR : SUPER WOOFER: 2.7 V 70EZ,K,V : SUPER WOOFER: 2.4 V SPEAKERS: accept speakers of 6 ohms or more SURROUND SPEAKERS: accept speakers of 16 ohms or more PHONES (stereo jack) : accepts headphones of 32 ohms or more

<Cassette deck section>

Track format	4 tracks, 2 channels stereo
Frequency response	CrO ₂ tape: 50 Hz – 16000 Hz Normal tape: 50 Hz – 15000 Hz
Signal-to noise ratio	60 dB (Dolby B NR ON, CrO ₂ tape peak level)
Recording system	AC bias
Heads	Deck 1 : playback head x 1 Deck 2 : Recording/Playback/erase head x 1

<Compact disc player section>

Laser	Semiconductor laser (λ =780 nm)
D-A converter	1 bit dual
Signal-to-noise ratio	90 dB (1 kHz, 0 dB)
Harmonic distortion	0.03 % (1 kHz, 0 dB)
Wow and flutter	Unmeasurable

<Speaker system SX-ANS70 (For NSX-S70)>

Cabinet type	4 way, bass reflex with surround speaker (magnetic shielded type)
Speakers	Woofer : 160 mm cone type Tweeter : 50 mm cone type Super tweeter : 20 mm ceramic type Cardioid speaker : 80 mm cone type Surround speaker : 80 mm
Impedance	Front speaker : 6 ohms Surround speaker : 16 ohms
Output sound pressure level	87 dB/W/m
Dimensions (W x H x D)	250 x 310 x 280 mm
Weight	4.5 kg

<Speaker system SX-NS74 (For NSX-S74)>

Cabinet type	3 way, bass reflex (magnetic shielded type)
Speakers	Woofer : 160 mm cone type Tweeter : 80 mm cone type Super tweeter: 20 mm ceramic type
Impedance	6 ohms
Output sound pressure level	87 dB/W/m
Dimensions (W x H x D)	243 x 304 x 245mm
Weight	3.8 kg

<General>

Power requirements	70(EZ,K,V) : 230 VAC, 50 Hz 74HR : 120 V/220-230V/240 V AC switchable, 50/60 Hz
Power consumption	70(EZ,K,V) : 150 W 74HR : 170 W
Dimensions of main unit (W x H x D)	70(EZ,K,V) : 260 x 309 x 370 mm 74HR : 260 x 309 x 363 mm
Weight of main unit	70(EZ,K,V) : 9.0 kg 74HR : 8.5 kg

• Design and specifications are subject to change without notice.

• Dolby noise reduction manufactured under license from Dolby Laboratories Licensing Corporation.
"DOLBY" and the double-D symbol  are trademarks of Dolby Laboratories Licensing Corporation.

• The word "BBE" and the "BBE symbol" are trademarks of BBE Sound, Inc.
Under license from BBE Sound, Inc.

PROTECTION OF EYES FROM LASER BEAM DURING SERVICING

This set employs laser. Therefore, be sure to follow carefully the instructions below when servicing.

WARNING!!

WHEN SERVICING, DO NOT APPROACH THE LASER EXIT WITH THE EYE TOO CLOSELY. IN CASE IT IS NECESSARY TO CONFIRM LASER BEAM EMISSION. BE SURE TO OBSERVE FROM A DISTANCE OF MORE THAN 30cm FROM THE SURFACE OF THE OBJECTIVE LENS ON THE OPTICAL PICK-UP BLOCK.



- Caution: Invisible laser radiation when open and interlocks defeated avoid exposure to beam.
- Advarsel: Usynlig laserstråling ved åbning, når sikkerhedsafbrydere er ude af funktion. Undgå udsættelse for stråling.

VAROITUS!

Laitteen Käyttäminen muulla kuin tässä käyttöohjeessa mainitulla tavalla saattaa altistaa käyttäjän turvallisuusluokan 1 ylittävälle näkymättömälle lasersäteilylle.

WARNING!

Om apparaten används på annat sätt än vad som specificeras i denna bruksanvisning, kan användaren utsättas för osynlig laserstrålning, som överskrider gränsen för laserklass 1.

Precaution to replace Optical block

(KSS-213B)

Body or clothes electrostatic potential could ruin laser diode in the optical block. Be sure ground body and workbench, and use the clothes do not touch the diode.

- 1) After the connection, remove solder shown in figure right.

CAUTION

Use of controls or adjustments or performance of procedures other than those specified herein may result in hazardous radiation exposure.

ATTENTION

L'utilisation de commandes, réglages ou procédures autres que ceux spécifiés peut entraîner une dangereuse exposition aux radiations.

ADVARSEL

Usynlig laserstråling ved åbning, når sikkerhedsafbrydere er ude af funktion. Undgå udsættelse for stråling.

This Compact Disc player is classified as a CLASS 1 LASER product.

The CLASS 1 LASER PRODUCT label is located on the rear exterior.

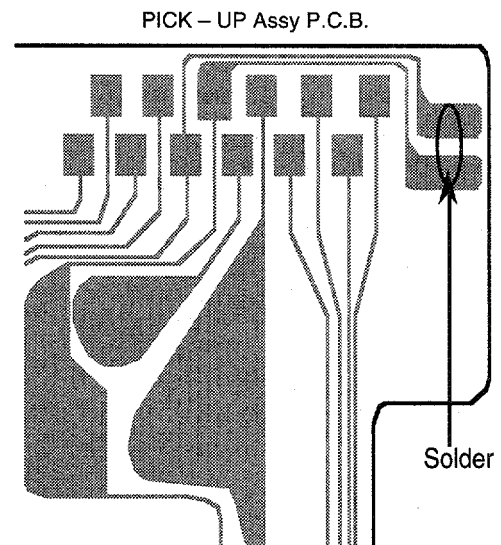
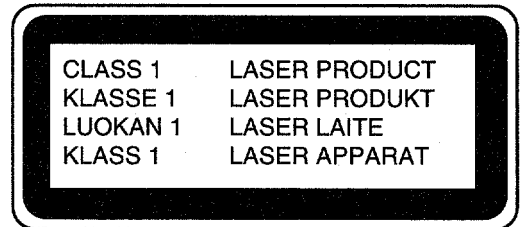

ELECTRICAL MAIN PARTS LIST

If can't understand for Description please kindly refer to "REFERENCE NAME LIST".

REF. NO.	PART NO.	KANRI NO.	DESCRIPTION	REF. NO.	PART NO.	KANRI NO.	DESCRIPTION
IC				C110	87-010-196-080		C-CAP,S 0.1-25 Z F C2012
	87-020-454-010	IC, DN6851		C111	87-010-196-080		C-CAP,S 0.1-25 Z F C2012
	87-NF4-642-010	IC, LC866548V-5E54		C112	87-010-196-080		C-CAP,S 0.1-25 Z F C2012
	87-070-083-010	IC, GPIU181X		C113	87-010-385-080		CAP,E 220-25 M SME<70EZ,K,V>
	87-A20-455-010	IC, HA12211		C113	87-010-408-080		CAP,E 47-50 SME<74HR>
	87-A20-355-010	IC, CXA1553P		C114	87-010-385-080		CAP,E 220-25 M SME<70EZ,K,V>
	87-A20-083-010	IC, BA3835S		C115	87-010-385-080		CAP,E 220-25 M SME<70EZ,K,V>
	87-A20-450-040	C-IC, BH3864F		C116	87-010-385-080		CAP,E 220-25 M SME<70EZ,K,V>
	87-A20-056-010	IC, BA3880S		C116	87-010-408-080		CAP,E 47-50 SME<74HR>
	87-A20-613-040	C-IC, BU9262AFS		C117	87-010-430-080		CAP,E 100-63
	87-A20-456-040	C-IC, BH3810FS		C118	87-010-263-080		CAP,E 100-10 SME
	87-017-888-080	C-IC, NJM4558MD		C119	87-010-260-080		CAP,E 47-25 SME
	86-NFZ-655-010	IC, LC72131D(Z)		C120	87-010-403-080		CAP,E 3.3-50 M SME
	87-A20-438-010	IC, LA1837		C121	87-012-140-080		C-CAP,S 470P-50 J CH
	87-A20-440-040	C-IC, BU1920FS<70EZ>		C123	87-010-247-080		CAP,E 100-50 M SME
				C124	87-010-112-080		CAP,E 100-16 M SME
				C125	87-010-235-080		CAP,E 470-16 SME
TRANSISTOR				C126	87-010-196-080		C-CAP,S 0.1-25 ZF C2012<70EZ,K,V>
	87-026-263-080	C-TR, RN1410		C127	87-010-196-080		C-CAP,S 0.1-25 ZF C2012<70EZ,K,V>
	89-213-702-010	TR, 2SB1370E		C129	87-010-393-080		CAP,E 100-35 M SME
	87-A30-076-080	C-TR, 2SC3052F		C200	87-010-196-080		C-CAP,S 0.1-25 ZF C2012<70EZ,K,V>
	87-A30-075-080	C-TR, 2SA1235F<74HR>		C201	87-010-400-080		CAP,E 0.47-50 M SME
	87-026-610-080	TR, KTC3198GR		C202	87-010-400-080		CAP,E 0.47-50 M SME
	87-A30-073-080	C-TR, RT1N 141C		C205	87-010-181-080		C-CAP,S 1800P-50 K B
	87-A30-085-070	C-TR, CSA1362GR		C206	87-010-181-080		C-CAP,S 1800P-50 K B
	87-A30-083-080	TR, CSD1489B		C207	87-010-404-080		CAP,E 4.7-50 M SME
	87-A30-084-080	TR, CSB1058B		C208	87-010-404-080		CAP,E 4.7-50 M SME
	87-A30-071-080	C-TR, RT1N 144C		C209	87-010-404-080		CAP,E 4.7-50 M SME
	87-026-609-080	TR, KTA1266GR		C210	87-010-404-080		CAP,E 4.7-50 M SME
	87-A30-086-070	C-TR, CSD1306E		C211	87-010-186-080		C-CAP,S 4700P-50 K B
	87-A30-106-070	C-TR, CMBT5551		C212	87-010-186-080		C-CAP,S 4700P-50 K B
	87-A30-111-080	TR, C2N5401		C213	87-010-260-080		CAP,E 47-25 SME
	87-A30-097-010	TR, FN1016		C214	87-010-260-080		CAP,E 47-25 SME
	87-A30-098-010	TR, FP1016		C215	87-010-196-080		C-CAP,S 0.1-25 Z F
	87-A30-089-010	FET, 2SK2723		C219	87-010-196-080		C-CAP,S 0.1-25 ZF C2012<70EZ,K,V>
	87-A30-072-080	C-TR, RT1P 144C		C219	87-012-368-080		C-CAP,S 0.1-50 FZ<74HR>
	87-A30-087-080	C-FET, 2SK2158		C220	87-010-196-080		C-CAP,S 0.1-25 ZF C2012<70EZ,K,V>
	87-A30-074-080	C-TR, RT1P 141C		C220	87-012-368-080		C-CAP,S 0.1-50 FZ<74HR>
	89-327-143-080	C-TR, 2SC2714(O)		C221	87-010-196-080		C-CAP,S 0.1-25 ZF C2012<70EZ,K,V>
	89-505-434-540	C-FET, 2SK543-TB(4/5)<70EZ,K,V>		C221	87-012-368-080		C-CAP,S 0.1-50 FZ<74HR>
				C222	87-010-196-080		C-CAP,S 0.1-25 ZF C2012<70EZ,K,V>
				C222	87-012-368-080		C-CAP,S 0.1-50 FZ<74HR>
DIODE				C223	87-010-194-080		C-CAP,S 0.047-25 Z F<74HR>
	87-017-654-060	DIODE, GBU6JL6131		C225	87-A10-516-080		C-CAP,S 100P-200 J CH
	87-017-437-080	DIODE, 1N4148M		C226	87-A10-516-080		C-CAP,S 100P-200 J CH
	87-A40-269-080	C-DIODE, MC2836		C227	87-018-134-080		CAP,TC U 0.01-16NYUP050<70EZ,K,V>
	87-A40-270-080	C-DIODE, MC2838		C228	87-018-131-080		CAP,TC U 1000P-50KB <70EZ,K,V>
	87-070-274-080	DIODE, 1N4003 SEM		C229	87-016-461-080		C-CAP,S 0.47-16 ZF
	87-A40-205-080	ZENER, UZ6.2BSC		C230	87-016-461-080		C-CAP,S 0.47-16 ZF
	87-A40-211-080	ZENER, UZ36BSA		C231	87-010-176-080		C-CAP,S 680P-50 J SL<70EZ,K,V>
	87-A40-206-080	ZENER, UZ10BSC		C232	87-010-176-080		C-CAP,S 680P-50 J SL<70EZ,K,V>
	87-A40-202-080	ZENER, UZ5.1BSB		C233	87-010-318-080		CAP,S 47P-50 J CH<70EZ,K,V>
	87-A40-184-090	DIODE, RK34(F)		C234	87-010-318-080		CAP,S 47P-50 J CH<70EZ,K,V>
	87-A40-246-080	DIODE, 1N4148T-72		C235	87-010-213-080		CAP,S 0.015-25 K B<70EZ,K,V>
	87-017-481-080	ZENER, UZ-5.6BSB		C236	87-010-197-080		C-CAP,S 0.01-25 K B<70EZ,K,V>
	87-A40-192-080	ZENER, UZ4.3BSA		C237	87-010-197-080		C-CAP,S 0.01-25 K B<70EZ,K,V>
	87-A40-239-080	ZENER, UZ5.6BSA		C238	87-010-197-080		C-CAP,S 0.01-25 K B<70EZ,K,V>
	87-A40-004-080	ZENER, MTZJ16A		C239	87-010-318-080		C-CAP,S 47P-50 J CH<70EZ,K,V>
				C240	87-010-318-080		C-CAP,S 47P-50 J CH<70EZ,K,V>
				C242	87-010-406-080		CAP,E 22-50 M SME
MAIN C.B				C243	87-010-197-080		C-CAP,S 0.01-25 K B
C101	87-A10-059-090	CAP,E 3300-75		C244	87-010-406-080		CAP,E 22-50 M SME
C102	87-A10-059-090	CAP,E 3300-75		C301	87-010-318-080		C-CAP,S 47P-50 J CH
C103	87-016-658-090	CAP,E 4700-35 M SMG		C302	87-010-318-080		C-CAP,S 47P-50 J CH
C104	87-016-658-090	CAP,E 4700-35 M SMG		C303	87-012-157-080		C-CAP,S 330P-50 J CH GRM
C105	87-012-368-080	C-CAP,S 0.1-50 Z F		C304	87-012-157-080		C-CAP,S 330P-50 J CH GRM
C106	87-012-368-080	C-CAP,S 0.1-50 Z F		C305	87-012-145-080		C-CAP,S 270P-50 J CH
C107	87-012-368-080	C-CAP,S 0.1-50 Z F		C306	87-012-145-080		C-CAP,S 270P-50 J CH
C108	87-012-368-080	C-CAP,S 0.1-50 Z F		C307	87-010-196-080		C-CAP,S 0.1-25 Z F C2012
C109	87-010-196-080	C-CAP,S 0.1-25 Z F C2012		C311	87-010-198-080		C-CAP,S 0.022-25 K B

REF. NO.	PART NO.	KANRI NO.	DESCRIPTION	REF. NO.	PART NO.	KANRI NO.	DESCRIPTION
C312	87-010-198-080		C-CAP,S 0.022-25 K B	C609	87-010-322-080		C-CAP,S 100P-50 J CH<70EZ,K,V>
C313	87-010-180-080		C-CAP,S 1500P-50 K B	C610	87-010-322-080		C-CAP,S 100P-50 J CH<70EZ,K,V>
C314	87-010-180-080		C-CAP,S 1500P-50 K B	C611	87-016-081-080		C-CAP,S 0.1-16 KR
C315	87-010-178-080		C-CAP,S 1000P-50 K B	C613	87-010-404-080		CAP,E 4.7-50 M SME
C316	87-010-178-080		C-CAP,S 1000P-50 K B	C614	87-010-404-080		CAP,E 4.7-50 M SME
C317	87-012-142-080		C-CAP,S 0.33-16 Z F	C615	87-010-183-080		C-CAP,S 2700P-50 K B<70EZ,K,V>
C318	87-012-142-080		C-CAP,S 0.33-16 Z F	C619	87-010-263-080		CAP,E 100-10 SME
C319	87-012-141-080		C-CAP,S 0.22-16 Z F	C620	87-010-196-080		C-CAP,S 0.1-25 Z F C2012
C320	87-012-141-080		C-CAP,S 0.22-16 Z F	C621	87-010-263-080		CAP,E 100-10 SME
C321	87-012-141-080		C-CAP,S 0.22-16 Z F	C622	87-010-196-080		C-CAP,S 0.1-25 Z F C2012
C322	87-012-141-080		C-CAP,S 0.22-16 Z F	C623	87-010-194-080		C-CAP,S 0.047-25 Z F
C324	87-010-260-080		CAP,E 47-25 SME	C629	87-012-368-080		C-CAP,S 0.1-50 FZ
C325	87-010-370-080		CAP,E 330-6.3 M SME	C630	87-010-196-080		C-CAP,S 0.1-25 ZF<70EZ,K,V>
C327	87-010-404-080		CAP,E 4.7-50 M SME	C632	87-010-196-080		C-CAP,S 0.1-25 ZF <70EZ,K,V>
C328	87-010-404-080		CAP,E 4.7-50 M SME	C631	87-015-785-080		C-CAP, 0.1-25 ZF <70EZ,K,V>
C332	87-010-196-080		C-CAP,S 0.1-25 Z F C2012	C633	87-010-197-080		C-CAP,S 0.01-25 K B<70EZ,K,V>
C335	87-010-401-080		CAP,E 1-50 M SME	C636	87-010-322-080		C-CAP,S 100P-50 J CH<70EZ,K,V>
C336	87-010-401-080		CAP,E 1-50 M SME	C637	87-010-322-080		C-CAP,S 100P-50 J CH<70EZ,K,V>
C337	87-010-196-080		C-CAP,S 0.1-25 Z F C2012	C646	87-010-322-080		C-CAP,S 100P-50 J CH
C339	87-010-196-080		C-CAP,S 0.1-25 Z F C2012	C647	87-010-322-080		C-CAP,S 100P-50 J CH
C340	87-010-196-080		C-CAP,S 0.1-25 Z F C2012	C701	87-010-381-080		CAP,E 330-16 SME
C351	87-012-140-080		C-CAP,S 470P-50 J CH	C702	87-010-404-080		CAP,E 4.7-50 M SME
C352	87-012-140-080		C-CAP,S 470P-50 J CH	C703	87-010-197-080		C-CAP,S 0.01-25 K B
C354	87-010-175-080		C-CAP,S 560P-50 J SL	C704	87-010-197-080		C-CAP,S 0.01-25 K B
C355	87-010-178-080		C-CAP,S 1000P-50 K B	C711	87-010-263-080		CAP,E 100-10 SME
C356	87-010-260-080		CAP,E 47-25 SME	C712	87-010-196-080		C-CAP,S 0.1-25 Z F C2012
C357	87-010-197-080		C-CAP,S 0.01-25 K B	C713	87-010-197-080		C-CAP,S 0.01-25 K B
C358	87-010-183-080		C-CAP,S 2700P-50 K B	C714	87-010-197-080		C-CAP,S 0.01-25 K B
C359	87-010-183-080		C-CAP,S 2700P-50 K B	C715	87-010-322-080		C-CAP,S 100P-50 J CH<70EZ,K,V>
C360	87-010-183-080		C-CAP,S 2700P-50 K B	C721	87-010-312-080		C-CAP,S 15P-50 J CH
C370	87-010-196-080		C-CAP,S 0.1-25 Z F C2012	C722	87-010-312-080		C-CAP,S 15P-50 J CH
C371	87-010-179-080		C-CAP,S 1200P-50 K B	C723	87-010-178-080		C-CAP,S 1000P-50 K B
C372	87-010-179-080		C-CAP,S 1200P-50 K B	C725	87-010-178-080		C-CAP,S 1000P-50 K B
C373	87-010-179-080		C-CAP,S 1200P-50 K B	C727	87-010-196-080		C-CAP,S 0.1-25 Z F C2012
C374	87-010-179-080		C-CAP,S 1200P-50 K B	C728	87-010-248-080		CAP,E 220-10 SME
C375	87-010-545-080		CAP,E 0.22-50 M SME	C755	87-010-197-080		C-CAP,S 0.01-25 K B
C376	87-010-545-080		CAP,E 0.22-50 M SME	C756	87-010-197-080		C-CAP,S 0.01-25 K B
C378	87-010-196-080		C-CAP,S 0.1-25 Z F C2012	C757	87-010-318-080		C-CAP,S 47P-50 J CH
C381	87-010-197-080		C-CAP,S 0.01-25 K B	C758	87-010-149-080		C-CAP,S 5P-50 CH
C382	87-010-318-080		C-CAP,S 47P-50 J CH	C761	87-010-196-080		C-CAP,S 0.1-25 Z F C2012
C383	87-010-197-080		C-CAP,S 0.01-25 K B	C762	87-010-197-080		C-CAP,S 0.01-25 K B
C384	87-010-402-080		CAP,E 2.2-50 M SME	C763	87-010-194-080		C-CAP,S 0.047-25 Z F
C385	87-010-184-080		C-CAP,S 3300P-50 K B	C765	87-010-197-080		C-CAP,S 0.01-25 K B
C386	87-010-196-080		C-CAP,S 0.1-25 Z F C2012	C766	87-010-197-080		C-CAP,S 0.01-25 K B
C388	87-010-154-080		C-CAP,S 10P-50 D CH	C767	87-010-405-080		CAP,E 10-50 M SME
C401	87-010-187-080		C-CAP,S 5600P-50 K B	C768	87-010-197-080		C-CAP,S 0.01-25 K B
C402	87-010-187-080		C-CAP,S 5600P-50 K B	C769	87-010-408-080		CAP,E 47-50 SME
C403	87-010-405-080		CAP,E 10-50 M SME	C770	87-015-821-080		C-CAP, 0.047-50 Z F GR
C404	87-010-405-080		CAP,E 10-50 M SME	C771	87-010-407-080		CAP,E 33-50 SME
C405	87-010-260-080		CAP,E 47-25 SME	C772	87-010-194-080		C-CAP,S 0.047-25 Z F
C406	87-010-101-080		CAP,E 220-16 SME	C773	87-010-196-080		C-CAP,S 0.1-25 Z F C2012
C407	87-010-188-080		C-CAP,S 6800P-50 K B	C774	87-010-263-080		CAP,E 100-10 SME
C408	87-010-188-080		C-CAP,S 6800P-50 K B	C775	87-010-404-080		CAP,E 4.7-50 M SME
C409	87-012-140-080		C-CAP,S 470P-50 J CH	C776	87-010-197-080		C-CAP,S 0.01-25 K B<70EZ,K,V>
C410	87-012-140-080		C-CAP,S 470P-50 J CH	C777	87-010-400-080		CAP,E 0.47-50 M SME
C411	87-010-197-080		C-CAP,S 0.01-25 K B	C778	87-010-401-080		CAP,E 1-50 M SME
C412	87-010-197-080		C-CAP,S 0.01-25 K B	C779	87-010-401-080		CAP,E 1-50 M SME
C413	87-010-195-080		C-CAP,S 0.068-25 Z F C2012	C780	87-010-196-080		C-CAP,S 0.1-25 Z F C2012
C414	87-010-195-080		C-CAP,S 0.068-25 Z F C2012	C781	87-010-405-080		CAP,E 10-50 M SME
C415	87-010-404-080		CAP,E 4.7-50 M SME	C782	87-010-405-080		CAP,E 10-50 M SME
C416	87-010-404-080		CAP,E 4.7-50 M SME	C783	87-015-819-080		C-CAP,0.01-50 K B
C417	87-010-404-080		CAP,E 4.7-50 M SME	C784	87-010-197-080		C-CAP,S 0.01-25 K B
C418	87-010-404-080		CAP,E 4.7-50 M SME	C785	87-010-400-080		CAP,E 0.47-50 M SME
C421	87-010-401-080		CAP,E 1-50 M SME	C786	87-010-400-080		CAP,E 0.47-50 M SME
C422	87-010-401-080		CAP,E 1-50 M SME	C787	87-010-184-080		C-CAP,S 3300P-50 K B
C516	87-010-196-080		C-CAP,S 0.1-25 Z F C2012	C788	87-010-184-080		C-CAP,S 3300P-50 K B
C601	87-010-322-080		C-CAP,S 100P-50 J CH<70EZ,K,V>	C789	87-010-179-080		C-CAP,S 1200P-50 K B
C602	87-010-322-080		C-CAP,S 100P-50 J CH<70EZ,K,V>	C790	87-010-179-080		C-CAP,S 1200P-50 K B
C605	87-010-180-080		C-CAP,S 1500P-50 K B<74HR>	C791	87-010-405-080		CAP,E 10-50 M SME
C606	87-010-180-080		C-CAP,S 1500P-50 K B	C793	87-010-178-080		C-CAP,S 1000P-50 KB<70K,V,74HR>

REF. NO.	PART NO.	KANRI NO.	DESCRIPTION	REF. NO.	PART NO.	KANRI NO.	DESCRIPTION
C793	87-012-156-080		C-CAP,S 220P-50 J CH GRM<70EZ>	L791	87-A50-027-010		COIL, 1 POLE MPX (TOK)
C794	87-010-406-080		CAP,E 22-50 M SME	L792	87-A50-027-010		COIL, 1 POLE MPX (TOK)
C795	87-010-596-080		C-CAP,S 0.047-16 K R	L941	87-A50-022-010		COIL,ANT SW (COI) 7.96MHZ<74HR>
C796	87-010-403-080		CAP,E 3.3-50 M SME	L941	87-A50-020-010		COIL,ANT LW (COI) 252KHZ<70EZ,K,V>
C797	87-010-180-080		C-CAP,S 1500P-50 K B	L942	87-A50-019-010		COIL,OSC LW (COI) 856KHZ<70EZ,K,V>
C798	87-010-180-080		C-CAP,S 1500P-50 K B	L942	87-A50-173-010		COIL,OSC SW-N (COI)<74HR>
C799	87-010-194-080		C-CAP,S 0.047-25 Z F	L943	87-005-372-080		COIL,1UH (K) LAL03<74HR>
C812	87-010-197-080		C-CAP,S 0.01-25 K B	L944	87-A50-159-010		COIL,10UH K C2B<74HR>
C814	87-010-197-080		C-CAP,S 0.01-25 K B	L981	86-NF4-666-010		COIL,AM PACK3 (TOK)<74HR>
C820	87-010-408-080		CAP,E 47-50 SME	L981	86-NF4-668-010		COIL,AM PACK 2 (TOM)<70EZ,K,V>
C821	87-010-197-080		C-CAP,S 0.01-25 K B	PR201	87-026-682-080		PROTECTOR,10A 491SERIES 60V
C822	87-010-197-080		C-CAP,S 0.01-25 K B	PR202	87-026-682-080		PROTECTOR,10A 491SERIES 60V
C823	87-010-197-080		C-CAP,S 0.01-25 K B	R123	87-022-200-080		RES,M/F 0.56-1W J<74HR>
C828	87-010-196-080		C-CAP,S 0.1-25 Z F C2012	R231	87-A00-262-080		RES,M/F 0.15-2W J
C829	87-010-196-080		C-CAP,S 0.1-25 Z F C2012	R232	87-A00-262-080		RES,M/F 0.15-2W J
C859	87-010-197-080		C-CAP,S 0.01-25 K B<70EZ>	RY101	87-045-389-010		RELAY,12V OSA-SS-212DM5
C861	87-010-156-080		C-CAP,S 220P-50 J CH<70EZ>	RY201	87-045-382-010		RELAY,12V OUAZ-SH-112L
C862	87-010-156-080		C-CAP,S 220P-50 J CH<70EZ>	SFR301	87-024-435-080		SFR,33K H RH063MC
C863	87-012-140-080		C-CAP,S 470P-50 J CH<70EZ>	SFR302	87-024-435-080		SFR,33K H RH063MC
C864	87-010-405-080		CAP,E 10-50 M SME<70EZ>	SFR303	87-024-435-080		SFR,33K H RH063MC
C865	87-010-196-080		C-CAP,S 0.1-25 ZF C2012<70EZ>	SFR304	87-024-435-080		SFR,33K H RH063MC
C866	87-010-405-080		CAP,E 10-50 M SME<70EZ>	SFR305	87-024-436-080		SFR,47K H RH063MC
C867	87-010-197-080		C-CAP,S 0.01-25 K B<70EZ>	SFR306	87-024-436-080		SFR,47K H RH063MC
C868	87-010-316-080		C-CAP,S 33P-50 J CH<70EZ>	SFR351	87-024-436-080		SFR,47K H RH063MC
C869	87-010-314-080		C-CAP,S 22P-50 J CH<70EZ>	SFR352	87-024-436-080		SFR,47K H RH063MC
C940	87-010-197-080		C-CAP,S 0.01-25 K B	TC941	87-011-220-080		TRIMMER,CER 20P 6.15X5.9<74HR>
C941	87-010-314-080		C-CAP,S 22P-50 J CH<74HR>	TC942	87-011-221-080		TRIMMER,CER 30P 6.15X5.9<74HR>
C942	87-010-151-080		C-CAP,S 7P-50 D CH<70EZ,K,V>	TC942	87-011-253-080		TRIMMER,30P LAK<70EZ,K,V>
C943	87-010-197-080		C-CAP,S 0.01-25 K B<74HR>	TH201	87-A90-221-080		C-THMS,100K
C944	87-014-051-080		CAP,PP 560P-100 J <74HR>	TH202	87-A90-221-080		C-THMS,100K
C945	87-010-197-080		C-CAP,S 0.01-25 K B<74HR>	W1	85-NF5-628-010		F-CABLE,7P-2.5
C947	87-010-197-080		C-CAP,S 0.01-25 K B	X721	87-A70-061-010		VIB,XTAL 4.500MHZ CSA-309
C949	87-014-049-080		CAP,PP 470P-100 J<70EZ,K,V>	X771	87-030-354-010		VIB,CER 450.0KHZ BFU C<74HR>
C950	87-014-073-080		CAP,PP 4700P-100 J <74HR>	X850	87-KT1-608-010		X,TAL 4.332MHZ<70EZ>
C952	87-010-197-080		C-CAP,S 0.01-25 K B				
C953	87-010-197-080		C-CAP,S 0.01-25 K B<74HR>	FRONT C.B			
C954	87-010-400-080		CAP,E 0.47-50 M SME<74HR>	C103	87-010-197-080		C-CAP,S 0.01-25 K B
C956	87-010-263-080		CAP,E 100-10 M SME<74HR>	C104	87-010-312-080		C-CAP,S 15P-50 J CH
C957	87-010-311-080		C-CAP,S 12P-50 J CH<70EZ,K,V>	C105	87-010-316-080		C-CAP,S 33P-50 J CH
C958	87-010-197-080		C-CAP,S 0.01-25 K B<70EZ,K,V>	C106	87-010-320-080		C-CAP,S 68P-50 J CH
C959	87-010-196-080		C-CAP,S 0.1-25 Z F C2012	C107	87-012-157-080		C-CAP,S 330P-50 J CH GRM
C960	87-010-196-080		C-CAP,S 0.1-25 Z F C2012	C108	87-010-560-040		CAP,E 10-50 M 5L MA
C962	87-010-401-080		CAP,E 1-50 M SME	C109	87-010-401-040		CAP,E 1-50 M SME
CF801	87-008-261-010		FLTR,CFSFE10.7MA5<74HR>	C110	87-010-196-080		C-CAP,S 0.1-25 Z F C2012
CF801	87-008-423-010		FLTR,IFSFE10.7MS3G-A<70EZ,K,V>	C111	87-010-196-080		C-CAP,S 0.1-25 Z F C2012
CF802	87-008-261-010		FLTR,CFSFE10.7MA5<74HR>	C112	87-010-196-080		C-CAP,S 0.1-25 Z F C2012
CF802	82-785-747-010		CF,MS2 GHY,R<70EZ,K,V>	C113	87-A10-189-040		CAP,E 220-10 M
FB301	87-008-372-080		FLTR,EMIBL01 RN1<70EZ,K,V>	C114	87-010-196-080		C-CAP,S 0.1-25 Z F C2012
FFE801	A8-7ZA-290-030		7ZA-2 FEUNM<74HR>	C115	87-010-178-080		C-CAP,S 1000P-50 K B
FFE801	A8-6ZA-195-030		6ZA-1 FEENM<70EZ,K>	C116	87-010-494-040		CAP,E 1-50 5L SRE
FFE801	A8-6ZA-193-030		6ZA-1 FEVNM<70V>	C117	87-010-555-040		CAP,E 100-10 5L SRE
J252	87-A60-024-010		JACK,DIA6.3 BLK ST W/SW KM	C118	87-010-194-080		C-CAP,S 0.047-25 Z F
J253	87-099-474-010		JACK,PIN 3P BLK W/SW	C119	87-010-408-040		CAP,E 47-50 M SME
J254	87-A60-238-010		TERMINAL,SP 4P (MSC)	C120	87-010-404-040		CAP,E 4.7-50 SME
J601	87-A60-426-010		JACK,PIN 6P YXC21-3835	C121	87-010-404-040		CAP,E 4.7-50 SME
J801	87-A60-202-010		TERMINAL,ANT4PMS-154V-02<74HR,70V>	C122	87-010-194-080		C-CAP,S 0.047-25 Z F
J801	87-A60-427-010		TERMINAL,ANT PAL 2P YKD3<70EZ,K>	C123	87-010-196-080		C-CAP,S 0.1-25 Z F C2012
J940	81-754-629-010		CONNECTOR,XH 2P(UL)<74HR>	C124	87-010-196-080		C-CAP,S 0.1-25 Z F C2012
L201	87-003-383-010		COIL,1UH K	C125	87-010-196-080		C-CAP,S 0.1-25 Z F C2012
L202	87-003-383-010		COIL,1UH K	C127	87-010-196-080		C-CAP,S 0.1-25 Z F C2012
L301	87-A50-049-010		COIL,TRAP 85K(COI)	C128	87-010-178-080		C-CAP,S 1000P-50 K B
L302	87-A50-049-010		COIL,TRAP 85K(COI)	C351	87-012-158-080		C-CAP,S 390P-50 J CH GRM
L351	87-007-342-010		COIL,OSC 85KHZ BIAS	C352	87-010-196-080		C-CAP,S 0.1-25 Z F C2012
L601	87-003-231-080		C-COIL,2125 1UH	C353	87-010-196-080		C-CAP,S 0.1-25 Z F C2012
L770	87-005-849-080		COIL,10UH K CECS	C354	87-010-196-080		C-CAP,S 0.1-25 Z F C2012
L771	87-A50-165-010		COIL,FM DET-N(TOK)	C355	87-010-196-080		C-CAP,S 0.1-25 Z F C2012
L772	87-A90-052-010		FLTR,CFMT-450A (TOK)<74HR>	C356	87-010-196-080		C-CAP,S 0.1-25 Z F C2012
L772	87-A90-245-010		FLTR,CPAZH-450 (TOK)<70EZ,K,V>	C357	87-010-196-080		C-CAP,S 0.1-25 Z F C2012
L850	87-005-847-080		COIL,2.2UH K CECS<70EZ>	C605	87-010-196-080		C-CAP,S 0.1-25 Z F C2012
L832	87-005-847-080		COIL,2.2UH K CECS				

REF. NO.	PART NO.	KANRI NO.	DESCRIPTION	REF. NO.	PART NO.	KANRI NO.	DESCRIPTION
FB601	87-008-372-080		FLTR,EMIBL01 RN1	C131	87-010-263-080		CAP,E 100-10 SME<74HR>
FL101	87-NF5-611-010		FL,BJ530GK 7NF-5	C132	87-010-380-080		CAP,E 47-16 M SME<74HR>
J601	87-A60-284-010		JACK,3.5MO (MSC)				
J602	87-A60-284-010		JACK,3.5MO (MSC)				
LED201	87-A40-317-080		LED,SLR-342VCT31 RED		AC2 C.B		
LED202	87-A40-317-080		LED,SLR-342VCT31 RED	△ PR1	87-026-682-080		PROTECTOR,10A 491SERIES 60V
LED203	87-A40-317-080		LED,SLR-342VCT31 RED	△ PR2	87-026-682-080		PROTECTOR,10A 491SERIES 60V
LED204	87-A40-317-080		LED,SLR-342VCT31 RED	△ PR5	87-026-691-080		FUSE,10A 125V 251
LED205	87-A40-317-080		LED,SLR-342VCT31 RED	△ PR6	87-026-682-080		PROTECTOR,10A 491SERIES 60V
LED206	87-A40-316-080		LED,SLR-56PCT31 GRN				
LED207	87-A40-316-080		LED,SLR-56PCT31 GRN		AC1 C.B		
LED208	87-A40-316-080		LED,SLR-56PCT31 GRN	△ FC1	87-033-147-010		FUSE CLAMP,MT-20<74HR>
LED209	87-A40-316-080		LED,SLR-56PCT31 GRN	△ FC1	87-A90-505-080		FUSE CLAMP,TP0351-5<70V>
LED210	87-A40-316-080		LED,SLR-56PCT31 GRN	△ FC1	87-033-213-080		FUSE CLAMP,PPC5000<70EZ,K>
LED211	87-A40-316-080		LED,SLR-56PCT31 GRN	△ FC2	87-033-147-010		FUSE CLAMP,MT-20<74HR>
LED212	87-A40-316-080		LED,SLR-56PCT31 GRN	△ FC2	87-A90-505-080		FUSE CLAMP,TP0351-5<70V>
LED213	87-A40-316-080		LED,SLR-56PCT31 GRN	△ FC2	87-033-213-080		FUSE CLAMP,PPC5000<70EZ,K>
LED214	87-A40-316-080		LED,SLR-56PCT31 GRN	△ FC3	87-033-147-010		FUSE CLAMP,MT-20<74HR>
LED215	87-A40-316-080		LED,SLR-56PCT31 GRN	△ FC4	87-033-147-010		FUSE CLAMP,MT-20<74HR>
LED216	87-A40-263-080		LED,SLH-56PCT31 GRN	△ F101	87-035-457-010		FUSE,3.15A 250V T218
LED217	87-A40-263-080		LED,SLH-56PCT31 GRN	△ F102	87-035-457-010		FUSE,3.15A 250V T218<74HR>
LED218	87-A40-263-080		LED,SLH-56PCT31 GRN	△ PT101	87-NF5-604-010		PT,HE EI85-58 7NF-5<74HR>
LED219	87-A40-263-080		LED,SLH-56PCT31 GRN	△ PT101	87-NF5-603-010		PT,E EI85-58 7NF-5<70EZ,K,V>
LED220	87-A40-263-080		LED,SLH-56PCT31 GRN	△ SW101	87-A90-165-010		SW,SL 1-2-3 SWS2301<74HR>
LED221	87-A40-263-080		LED,SLH-56PCT31 GRN	△ T1	87-A60-317-010		TERMINAL, 1P MSC
LED233	87-A40-265-010		LED,SLH-56PCL GRN	△ T2	87-A60-317-010		TERMINAL, 1P MSC
LED234	87-A40-265-010		LED,SLH-56PCL GRN				
LED235	87-A40-267-010		LED,SLH-56VCL RED		AUDIO C.B		
LED236	87-A40-267-010		LED,SLH-56VCL RED				
LED237	87-A40-265-010		LED,SLH-56PCL GRN				
LED238	87-A40-265-010		LED,SLH-56PCL GRN	C403	87-010-992-080		C-CAP,S 0.047-25 K B MK212
S301	87-A90-095-080		SW,TACT EVQ11G04M	C404	87-010-992-080		C-CAP,S 0.047-25 K B MK212
S302	87-A90-095-080		SW,TACT EVQ11G04M	C405	87-010-401-040		CAP,E 1-50 M SME
S303	87-A90-095-080		SW,TACT EVQ11G04M	C406	87-010-401-040		CAP,E 1-50 M SME
S304	87-A90-095-080		SW,TACT EVQ11G04M	C407	87-010-184-080		C-CAP,S 3300P-50 K B
S305	87-A90-095-080		SW,TACT EVQ11G04M	C408	87-010-184-080		C-CAP,S 3300P-50 K B
S306	87-A90-095-080		SW,TACT EVQ11G04M	C409	87-010-592-080		C-CAP,S 0.022-16 K R
S307	87-A90-095-080		SW,TACT EVQ11G04M	C410	87-010-592-080		C-CAP,S 0.022-16 K R
S308	87-A90-095-080		SW,TACT EVQ11G04M	C411	87-016-463-080		C-CAP, 0.33-16 K B C3216
S314	87-A90-095-080		SW,TACT EVQ11G04M	C412	87-016-463-080		C-CAP, 0.33-16 K B C3216
S315	87-A90-095-080		SW,TACT EVQ11G04M	C413	87-010-196-080		C-CAP,S 0.1-25 Z F C2012
S316	87-A90-095-080		SW,TACT EVQ11G04M	C414	87-010-374-040		CAP,E 47-10 SME
S317	87-A90-095-080		SW,TACT EVQ11G04M	C415	87-010-374-040		CAP,E 47-10 SME
S318	87-A90-095-080		SW,TACT EVQ11G04M	C416	87-010-196-080		C-CAP,S 0.1-25 Z F C2012
S319	87-A90-095-080		SW,TACT EVQ11G04M	C417	87-016-081-080		C-CAP,S 0.1-16 K R
S320	87-A90-095-080		SW,TACT EVQ11G04M	C418	87-010-405-040		CAP,E 10-50 M SME
S322	87-A90-095-080		SW,TACT EVQ11G04M	C501	87-010-319-080		C-CAP,S 56P-50 J CH
S328	87-A90-095-080		SW,TACT EVQ11G04M	C502	87-010-319-080		C-CAP,S 56P-50 J CH
S329	87-A90-095-080		SW,TACT EVQ11G04M	C503	87-012-393-080		C-CAP,S 0.22-16 K W5R CM/CB
S330	87-A90-095-080		SW,TACT EVQ11G04M	C504	87-010-197-080		C-CAP,S 0.01-25 K B
S331	87-A90-095-080		SW,TACT EVQ11G04M	C505	87-010-180-080		C-CAP,S 1500P-50 K B
S332	87-A90-095-080		SW,TACT EVQ11G04M	C506	87-010-213-080		C-CAP,S 0.015-25 K B
S336	87-A90-095-080		SW,TACT EVQ11G04M	C507	87-010-213-080		C-CAP,S 0.015-25 K B
S339	87-A90-095-080		SW,TACT EVQ11G04M<70EZ>	C508	87-010-197-080		C-CAP,S 0.01-25 K B
S340	87-A90-095-080		SW,TACT EVQ11G04M<70EZ>	C509	87-010-181-080		C-CAP,S 1800P-50 K B
S341	87-A90-095-080		SW,TACT EVQ11G04M<70EZ>	C510	87-010-196-080		C-CAP,S 0.1-25 Z F C2012
X101	87-A70-070-080		VIB,CER 5.76MHZ CRHF	C511	87-010-196-080		C-CAP,S 0.1-25 Z F C2012
				C512	87-010-374-040		CAP,E 47-10 SME
				C513	87-010-404-040		CAP,E 4.7-50 SME
				C514	87-010-404-040		CAP,E 4.7-50 SME
CD KEY C.B				C515	87-010-183-080		C-CAP,S 2700P-50 K B
S309	87-A90-095-080		SW,TACT EVQ11G04M	C516	87-010-183-080		C-CAP,S 2700P-50 K B
S310	87-A90-095-080		SW,TACT EVQ11G04M	C518	87-010-196-080		C-CAP,S 0.1-25 Z F C2012
S311	87-A90-095-080		SW,TACT EVQ11G04M	C519	87-010-263-040		CAP,E 100-10 M SME
S312	87-A90-095-080		SW,TACT EVQ11G04M	C533	87-010-545-080		CAP,E 0.22-50 M SME
S313	87-A90-095-080		SW,TACT EVQ11G04M	C601	87-010-405-040		CAP,E 10-50 M SME
FAN C.B				C602	87-010-186-080		C-CAP,S 4700P-50 K B
	87-A90-463-010		FAN,2408 NL<74HR>	C603	87-010-405-040		CAP,E 10-50 M SME
C130	87-010-401-080		CAP,E 1-50 M SME<74HR>	C604	87-010-382-040		CAP,E 22-25 SME
				C607	87-010-321-080		C-CAP,S 82P-50 J CH

REF. NO.	PART NO.	KANRI NO.	DESCRIPTION	REF. NO.	PART NO.	KANRI NO.	DESCRIPTION
C608	87-010-196-080		C-CAP,S 0.1-25 Z F C2012	SW2	87-A90-248-019		SW,MICRO ESE11SH2CXQ
C609	87-010-545-040		CAP,E 0.22-50 M SME	SW3	87-A90-248-019		SW,MICRO ESE11SH2CXQ
C611	87-010-177-080		C-CAP,S 820P-50 J SL	SW4	87-036-110-010		SW,MICRO SPPB62
C614	87-010-248-040		CAP,E 220-10 M SME	SW5	87-036-110-010		SW,MICRO SPPB62
L501	87-005-212-080		COIL,220UH K EL0606	SW6	87-036-110-010		SW,MICRO SPPB62
RE C.B				SW8	87-A90-248-019		SW,MICRO ESE11SH2CXQ
C101	87-010-198-080		C-CAP,S 0.022-25 K B	SW9	87-036-110-010		SW,MICRO SPPB62
C102	87-010-198-080		C-CAP,S 0.022-25 K B	CON502	87-099-756-019		CONN, 15P 9604 S F
S101	87-A90-535-010		SW,RTRY EC16B24304-WO NON	HEAD-1 C.B			
S326	87-A90-095-080		SW,TACT EVQ11G04M		85-ZM3-602-010		PWB,FLEX A
S327	87-A90-095-080		SW,TACT EVQ11G04M	HEAD-2 C.B			
DECK C.B					85-ZM3-602-010		PWB,FLEX A
W001	82-ZM3-601-019		RBN,CORD,4P-75				
SFR1	87-024-581-019		SFR,3.3K DIA 6H				
SOL1	82-ZM1-618-010		SOL ASSY, 27				
SOL2	82-ZM1-618-010		SOL ASSY, 27				
SW1	87-A90-248-019		SW,MICRO ESE11SH2CXQ				

TRANSISTOR ILLUSTRATION



ECB

KTA1266GR
KTC3198GR



ECB

CSD1489B
CSB1058B



EBC

C2N5401



BCE

2SB1370
FN1016
FP1016



GDG

2SK2723

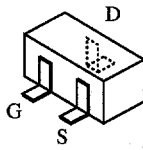

2SK2158

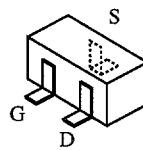

2SK543-TB(4/5)

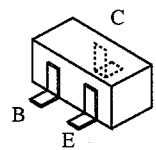

2SA1235F	RN1404
2SC2714	RT1N141C
2SC3052F	RT1N144C
CMBT5551	RT1P141C
CSA1362GR	RT1P144C
CSD1306E	

FL GRID ASSIGNMENT & ANODE CONNECTION

FL, BJ530GK

GRID ASSIGNMENT

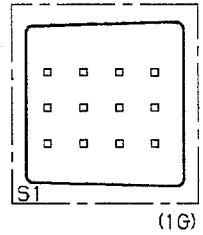
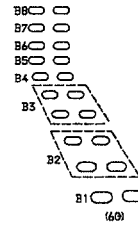
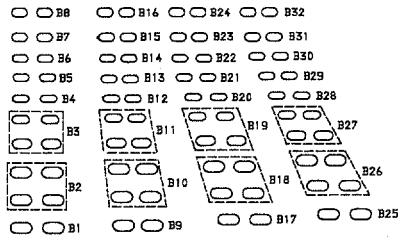
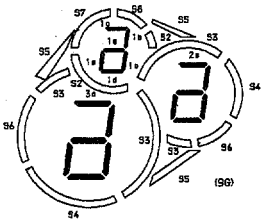
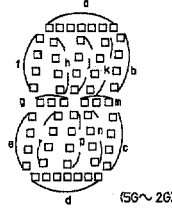
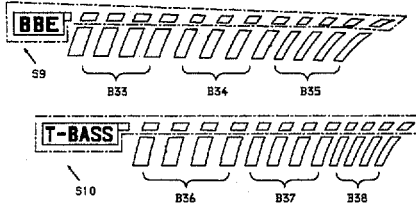
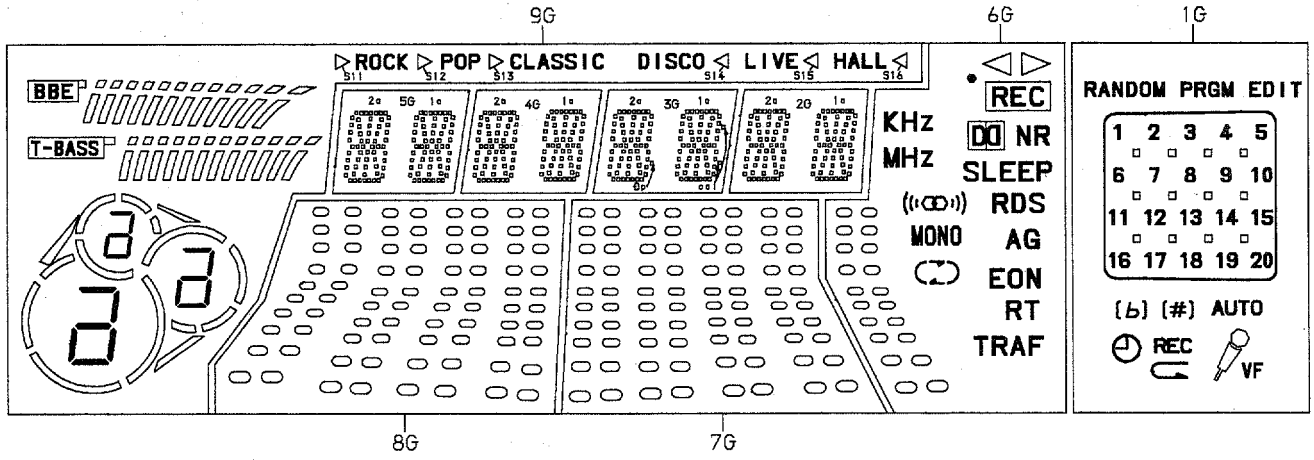

[8G, 7G]

ANODE CONNECTION

	9G	8G, 7G	6G	5G, 4G	3G	2G	1G
P1	S8	B32		-	col (down)	-	RANDOM
P2	S2	B24		1d	1d	1d	-
P3	1b	B16	SLEEP	1n	1n	1n	PRGM
P4	1c	B8	B8	1p	1p	1p	EDIT
P5	1e	B31		1r	1r	1r	1
P6	1a, 1d, 1g	B23	REC	1e	1e	1e	2
P7	2b	B15	KHz	1c	1c	1c	3
P8	2c	B7	B7	1g	1g	1g	4
P9	2e	B30	MHz	1m	1m	1m	5
P10	2a, 2d, 2g	B22	-	1f	1f	1f	6
P11	3b	B14		1b	1b	1b	7
P12	3c	B6	B6	1k	1k	1k	8
P13	3e	B29	RDS	1j	1j	1j	9
P14	3a, 3d, 3g	B21	-	1h	1h	1h	10
P15	S3	B13	-	1a	1a	1a	11
P16	S5	B5	B5	-	col (up)	-	12
P17	S7	B28	-	-	θp	-	13
P18	S4	B20	-	2d	2d	2d	14
P19	S6	B12	-	2n	2n	2n	15
P20	S16	B4	B4	2p	2p	2p	16
P21	S15	B27	AG	2r	2r	2r	17
P22	S14	B19		2e	2e	2e	18
P23	S13	B11	EON	2c	2c	2c	19
P24	S12	B3	B3	2g	2g	2g	20
P25	S11	B26	RT	2m	2m	2m	AUTO
P26	B36	B18	MONO	2f	2f	2f	VF
P27	B37	B10	TRAF	2b	2b	2b	
P28	B38	B2	B2	2k	2k	2k	REC
P29	B33	B25		2j	2j	2j	
P30	B34	B17		2h	2h	2h	(#)
P31	B35	B9		2a	2a	2a	((b))
P32	ROCK POP CLASSIC S10	B1	B1	-	-	-	S1
P33	DISCO LIVE HALL	-	-	-	-	-	-
P34	S9	-	-	-	-	-	-
P35	-	-	-	-	-	-	b #

IC BLOCK DIAGRAM - 1
IC, BA3880S

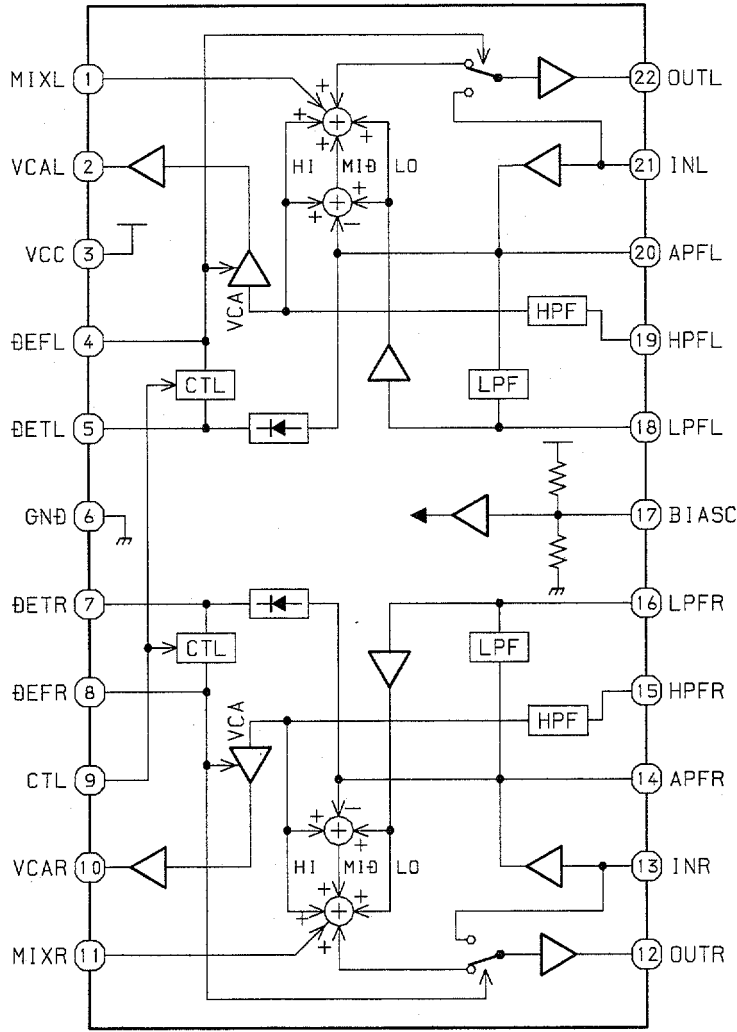

IC, HA12211NT

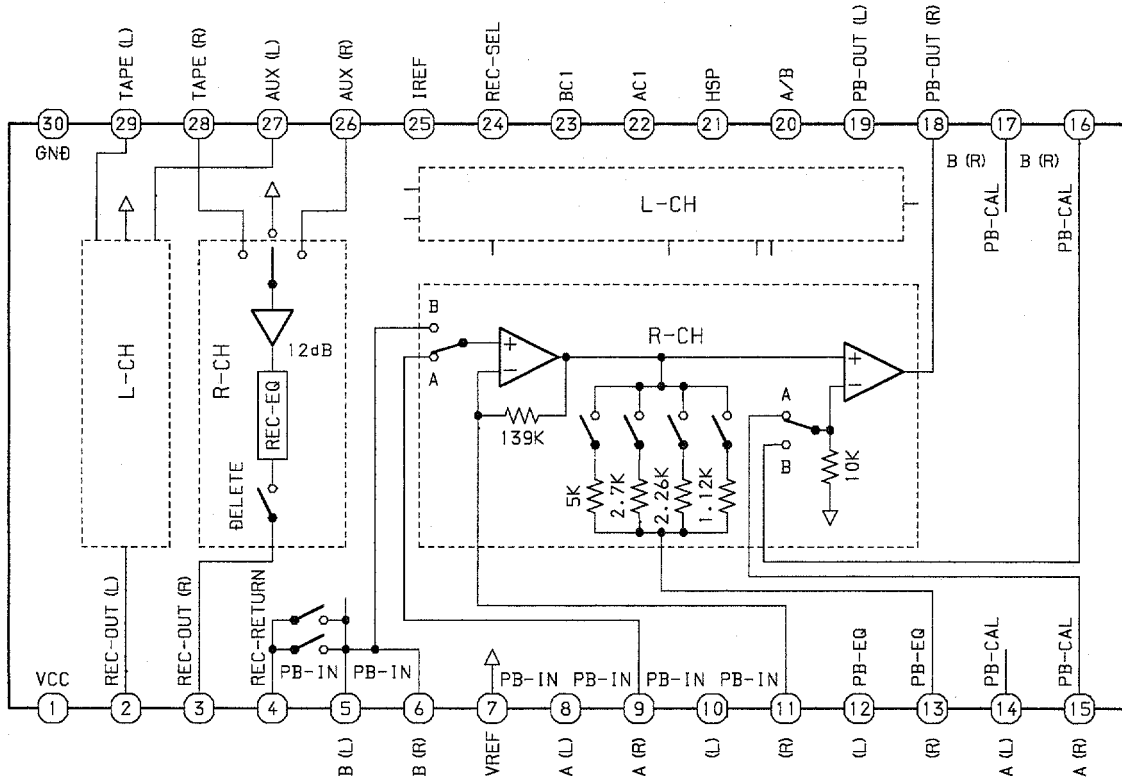

BLOCK DIAGRAM (MAIN / FRONT)

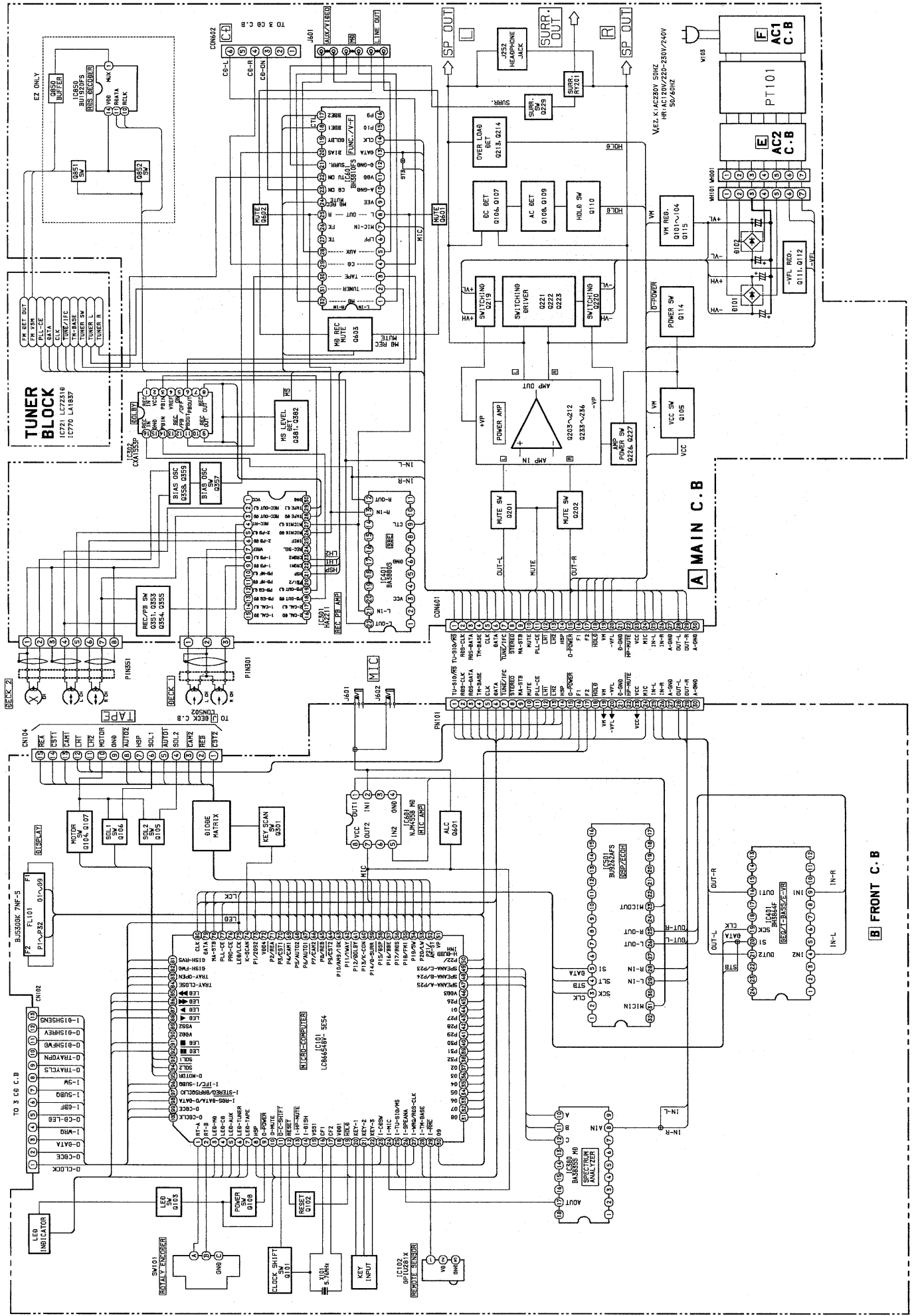

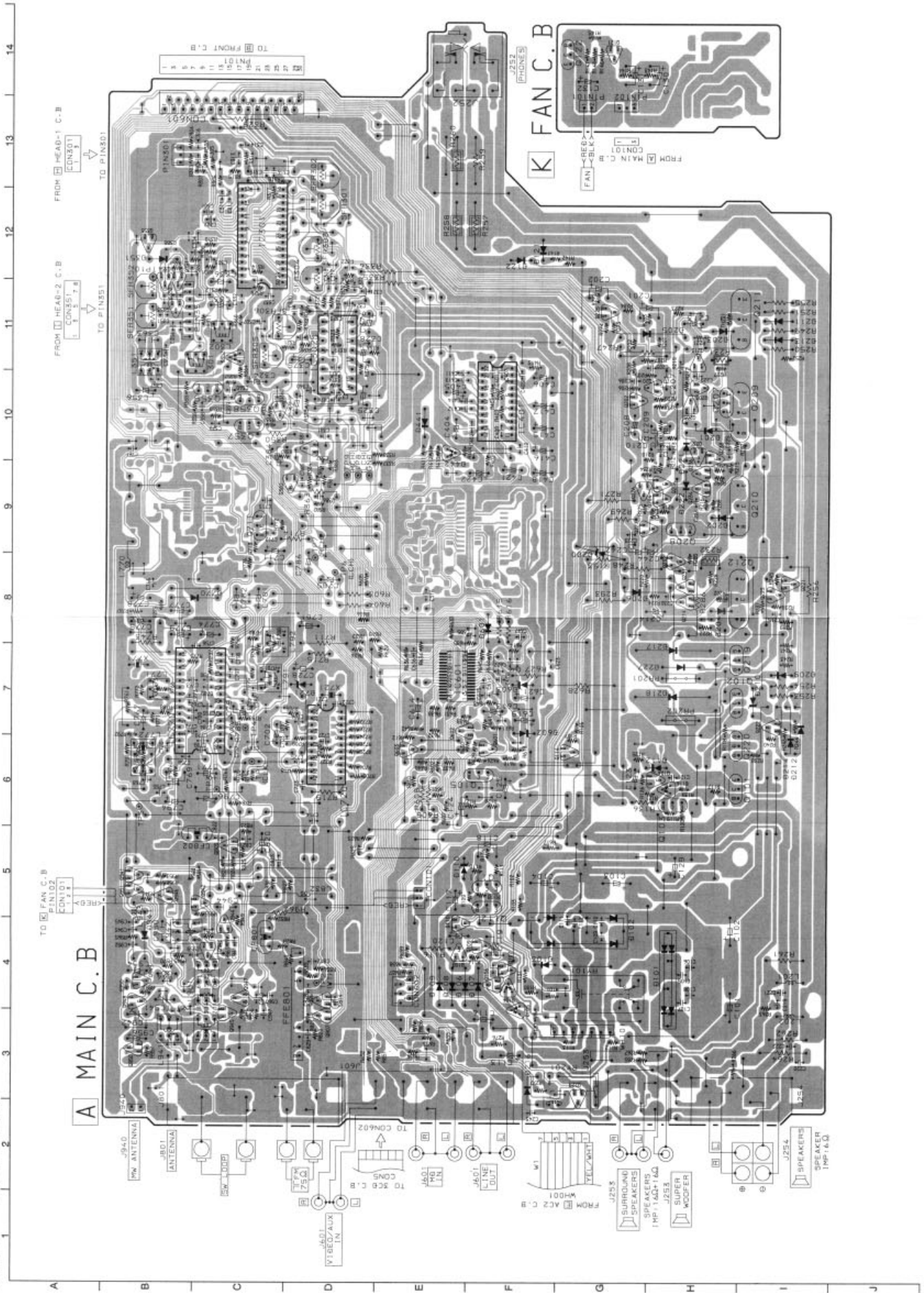

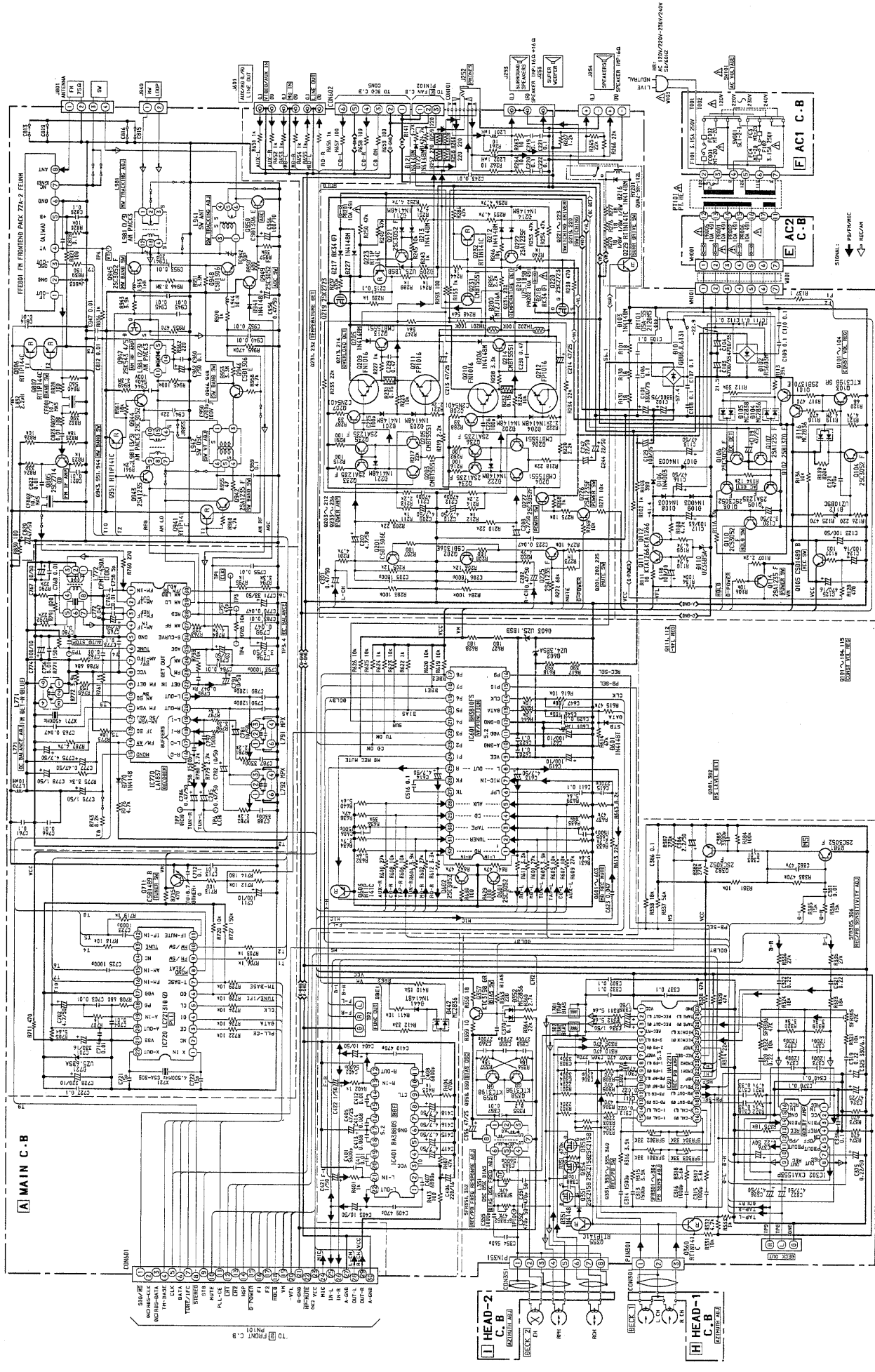

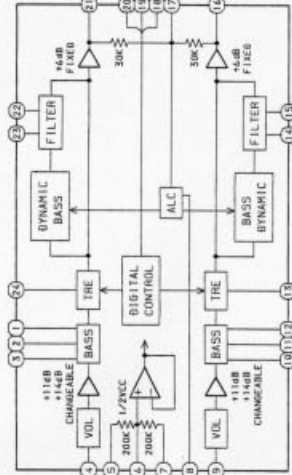

IC, BH13810FS

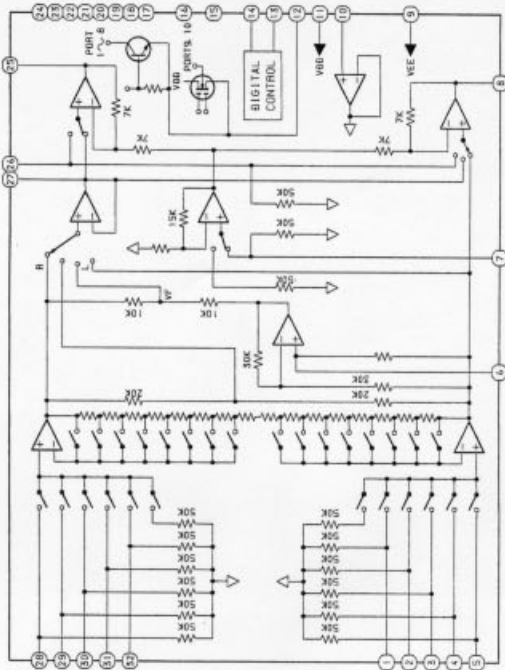

IC, BA3833S

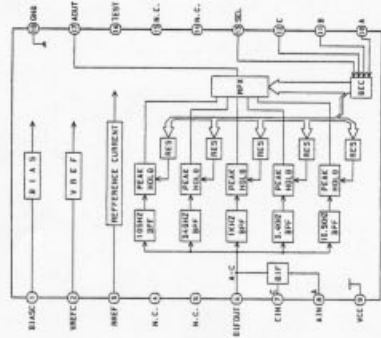

IC, LA1837

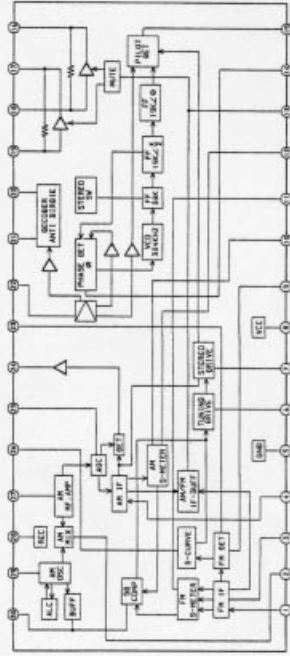

IC, BU9262FS

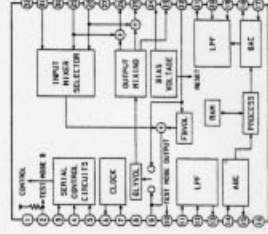

WIRING - 2 (MAIN : EZ, K, V)

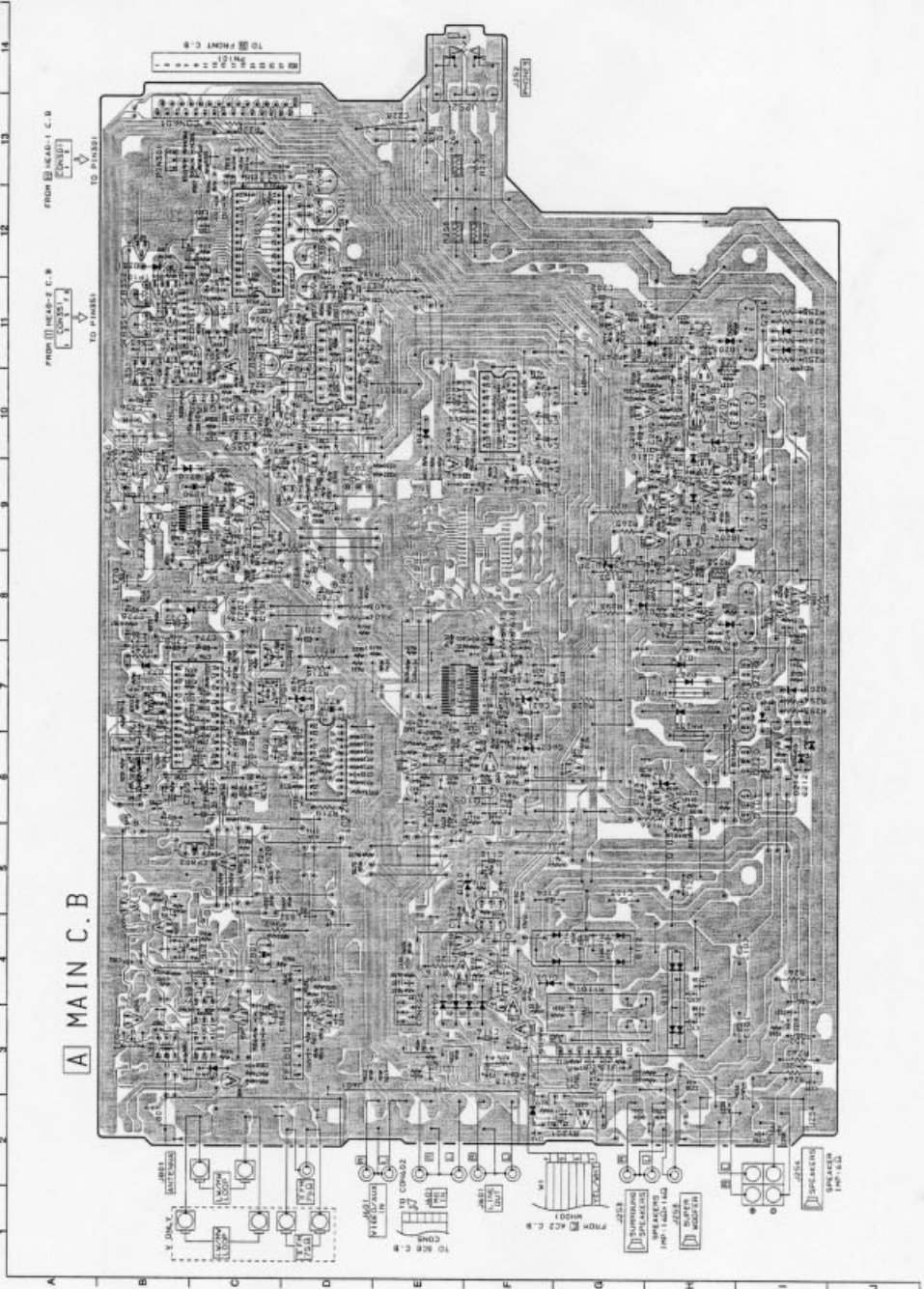

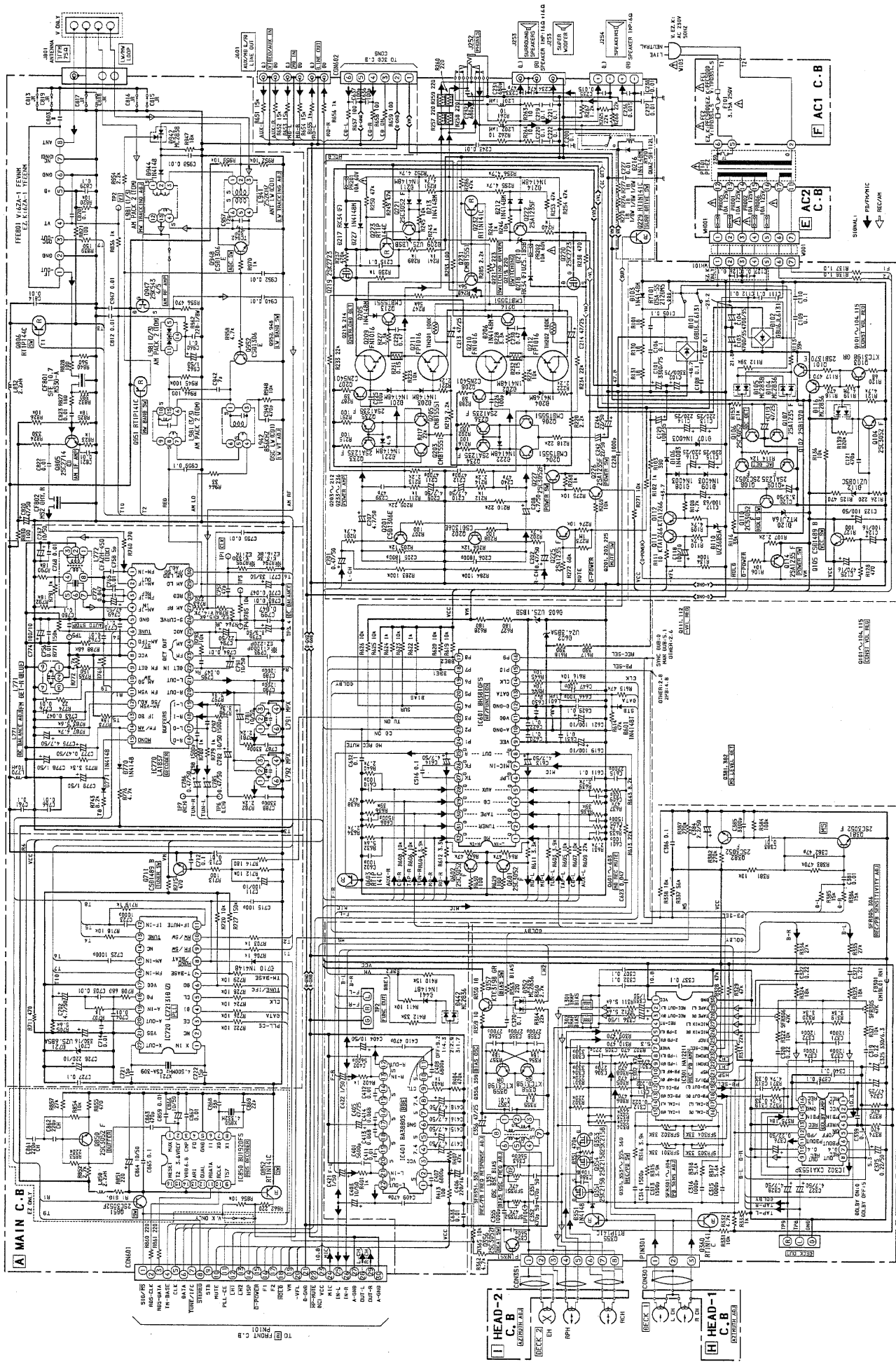

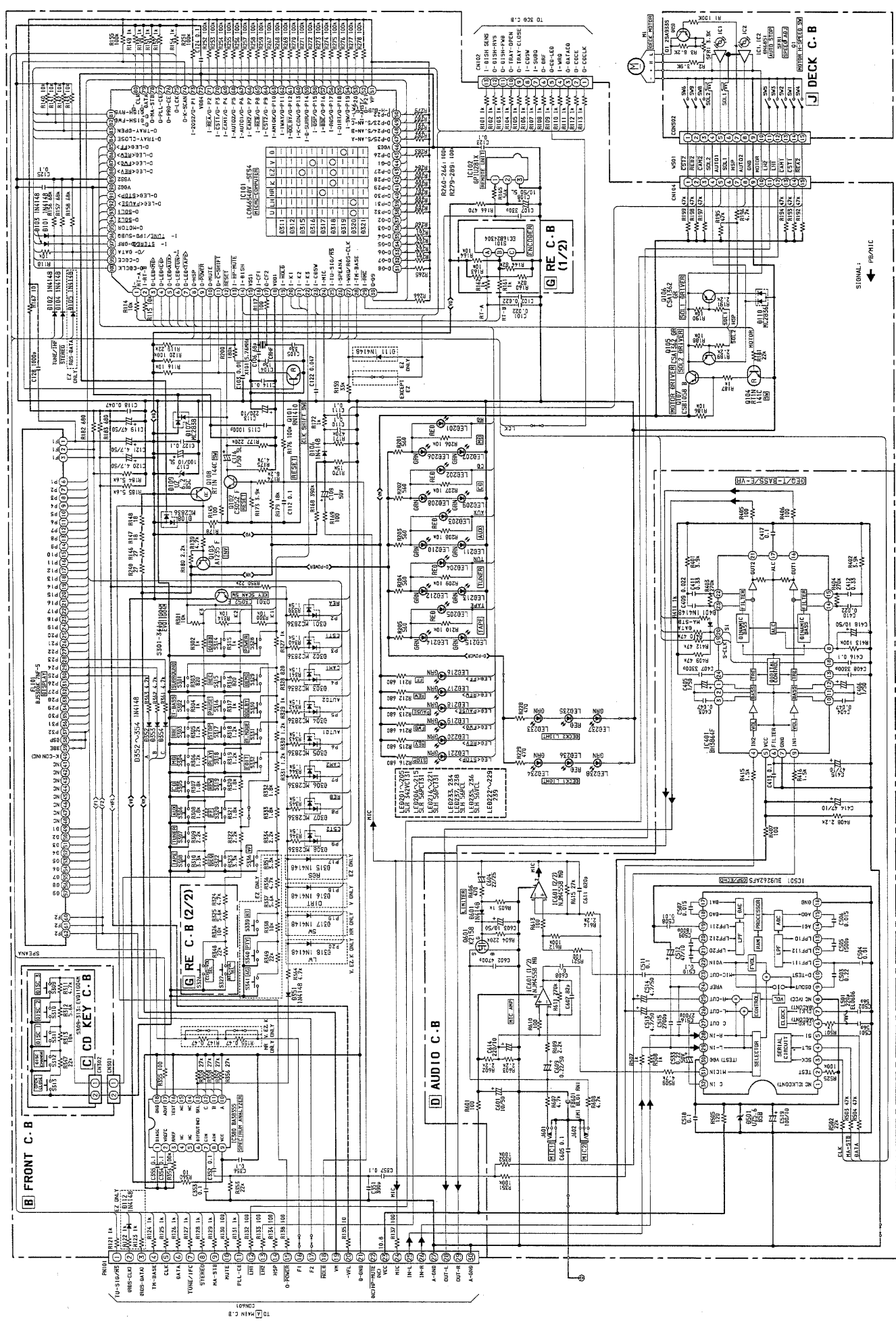

WIRING - 4 (PT)

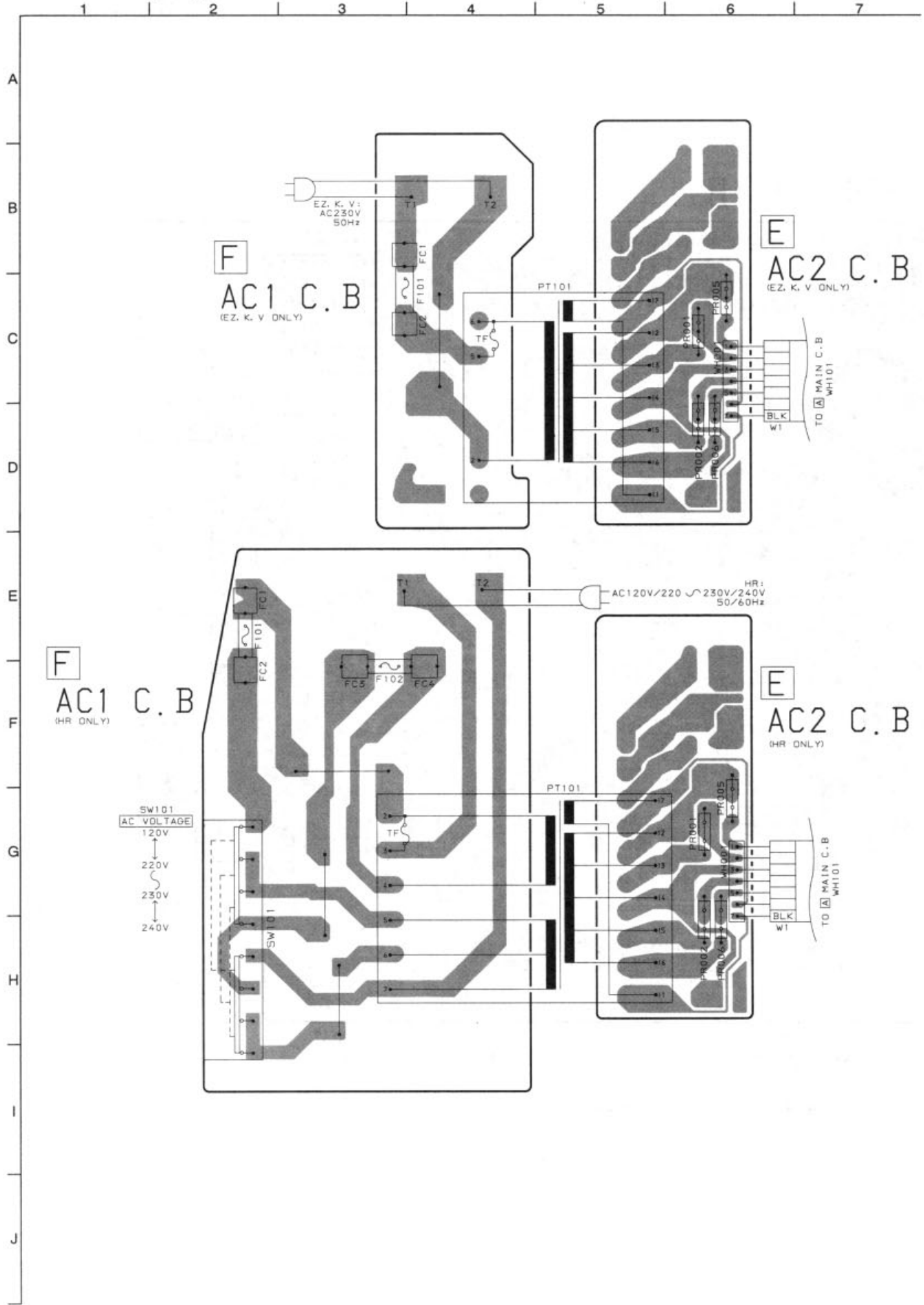

WIRING - 5 (DECK)

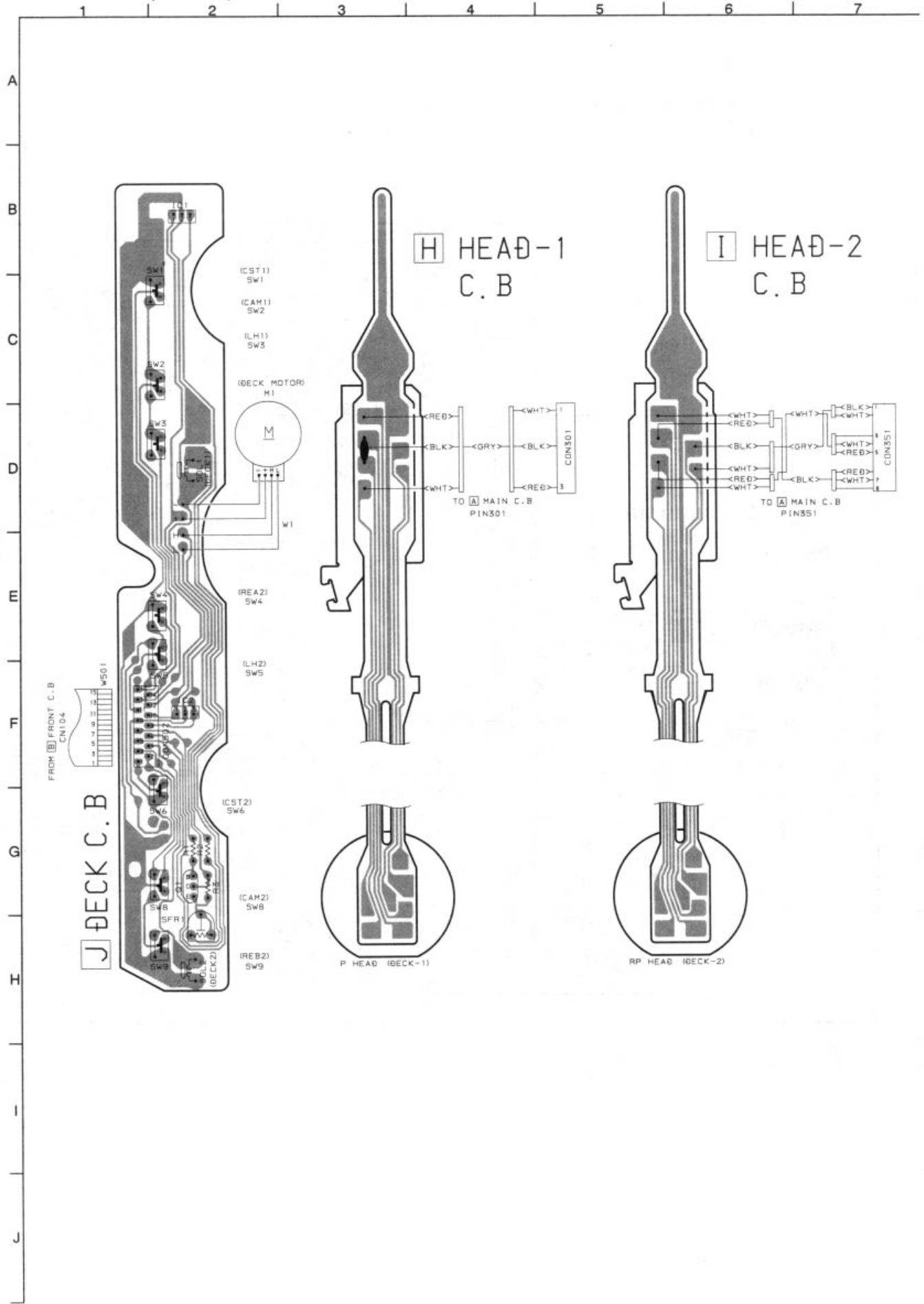

SCHEMATIC DIAGRAM - 4 (TUNER FRONT END / FAN)

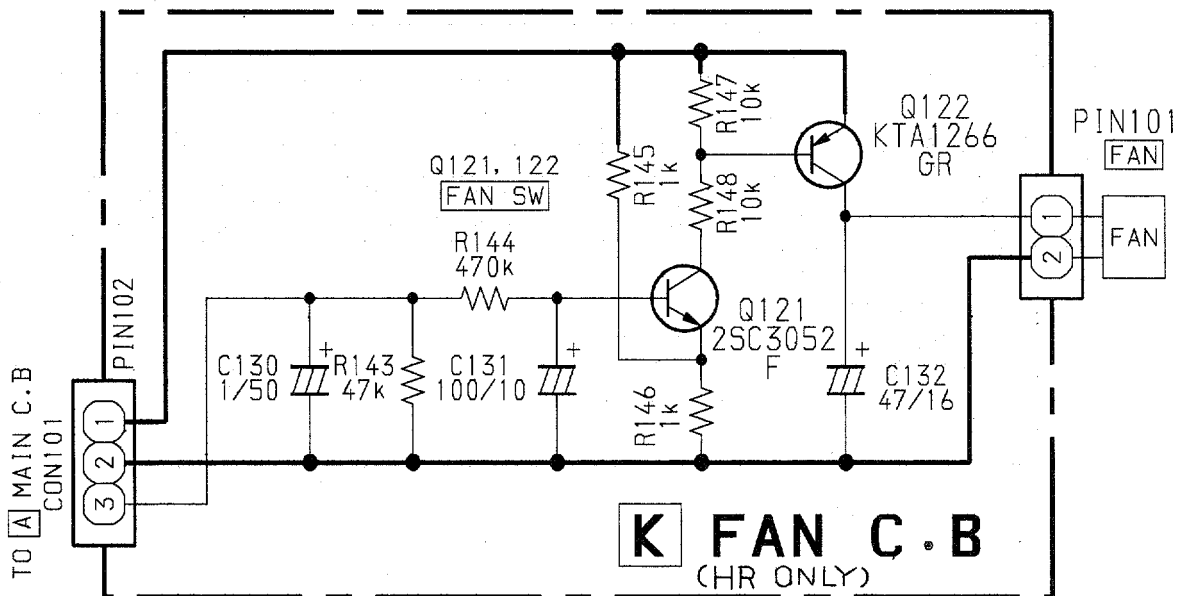
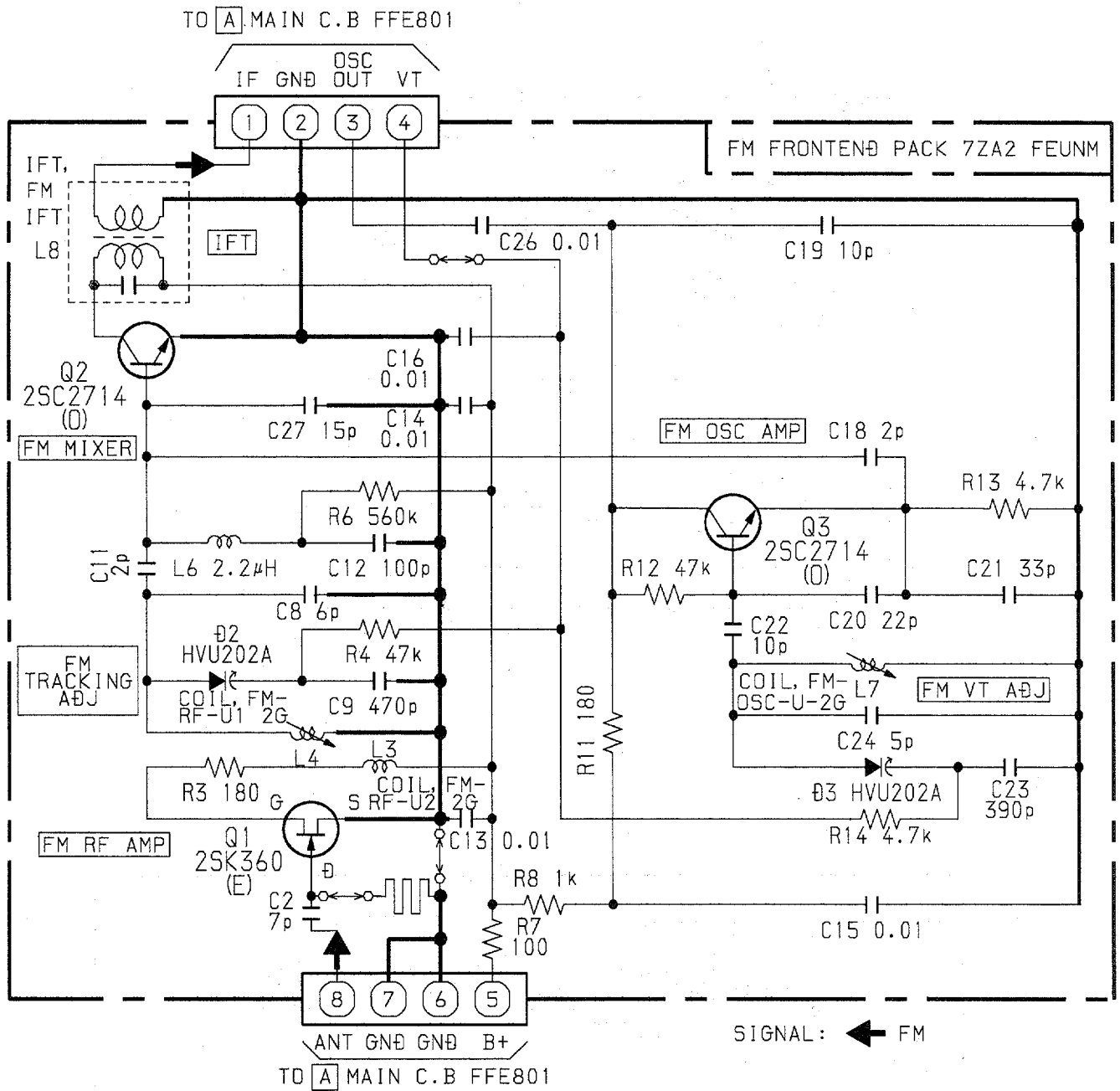

IC BLOCK DIAGRAM - 3
 IC, CXA1553P

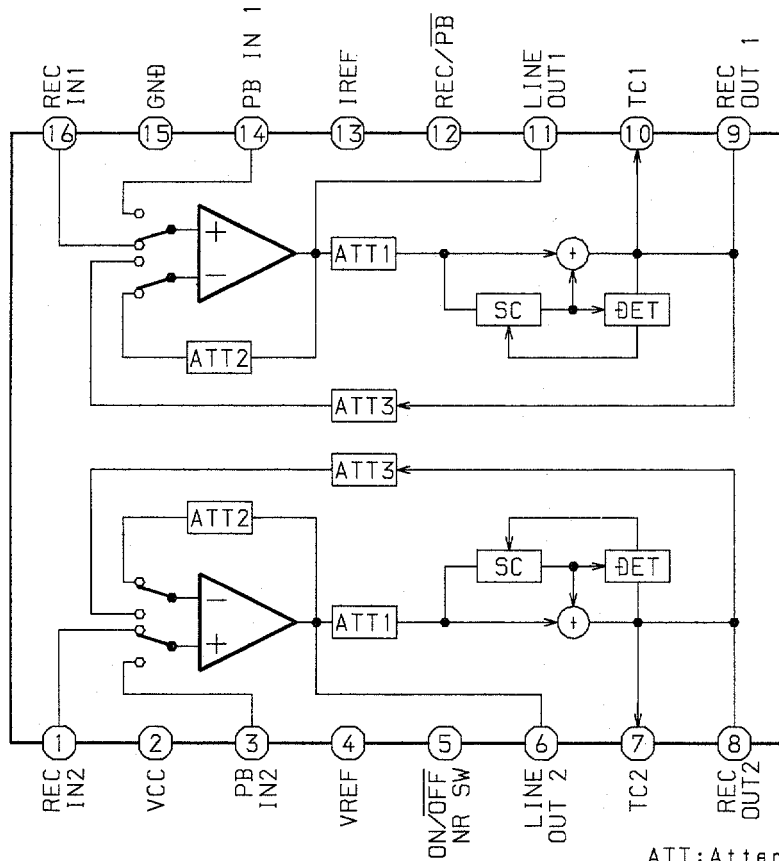

ATT:Attenuator
 SC:Side Chain
 DET:Detector

IC, BU1920FS

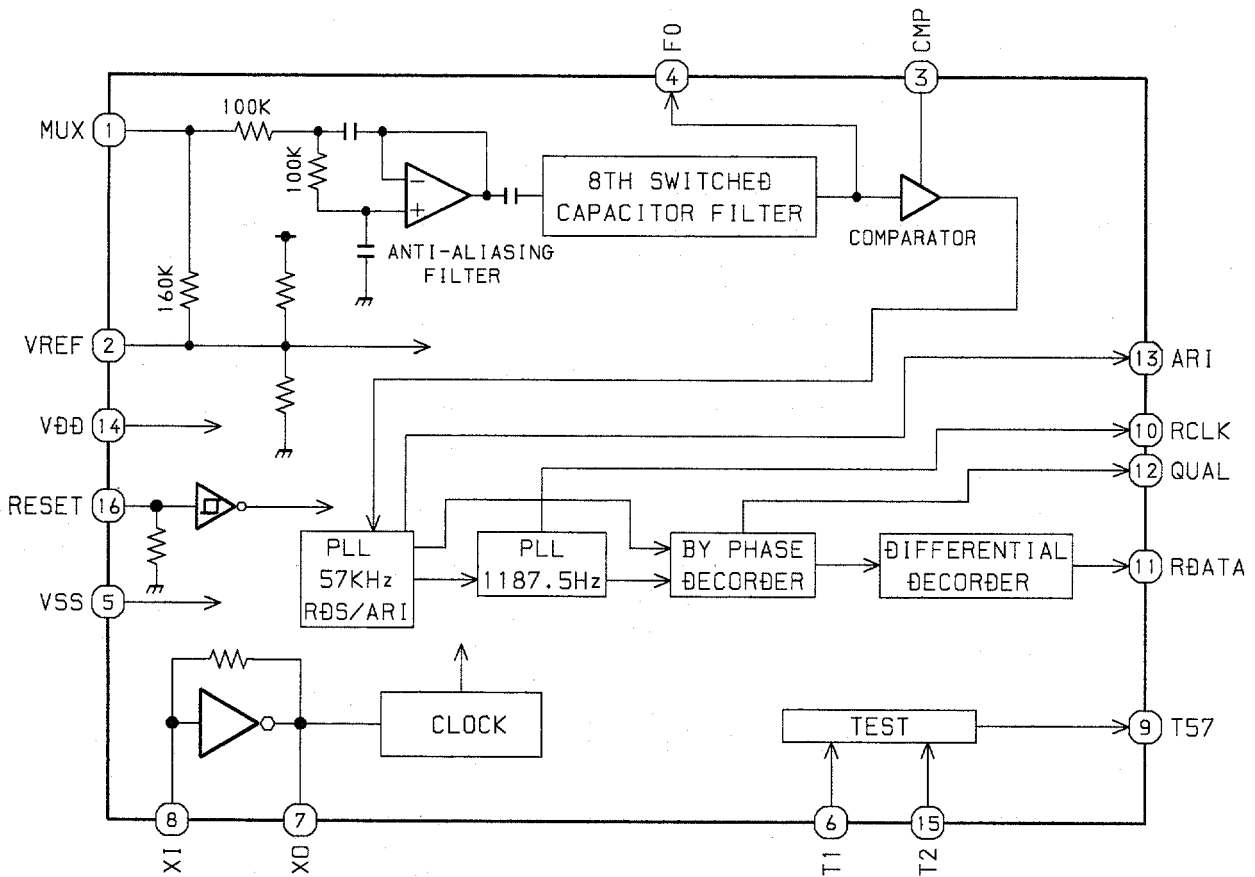

IC DESCRIPTION

IC, LC866548V-5E54

Pin No.	Pin Name	I/O	Description
1	RT-A	I	Rotary encoder A input.
2	RT-B	I	Rotary encoder B input.
3	$\overline{\text{LED-MD}}$	O	"MD" LED ON/OFF output.
4	$\overline{\text{LED-CD}}$	O	"CD" LED ON/OFF output.
5	$\overline{\text{LED-AUX}}$	O	"AUX" LED ON/OFF output.
6	$\overline{\text{LED-TUNER}}$	O	"TUNER" LED ON/OFF output.
7	$\overline{\text{LED-TAPE}}$	O	"TAPE" LED ON/OFF output.
8	HSP	O	Tape deck motor high speed ON/OFF output.
9	$\overline{\text{O-POWER}}$	O	System power supply ON/OFF output.
10	$\overline{\text{O-MUTE}}$	O	System mute ON/OFF output.
11	$\overline{\text{O-CLK-SHIFT}}$	O	U-COM clock shift output.
12	$\overline{\text{RESET}}$	I	Reset input.
13	$\overline{\text{I-HP-MUTE}}$	-	Not connected.
14	I-DISH	I	CD turntable photo sensor A/D converter input.
15	VSS 1	-	GND.
16	CF 1	-	5.76MHz oscillator circuit.
17	CF 2	-	
18	VDD 1	-	Power supply input.
19	$\overline{\text{HOLD}}$	I	Power failure detected input "1" to stop clock and main memory.
20	KEY-1	I	KEY input.(A/D)
21	KEY-2	I	
22	KEY-3	I	
23	I-CD SW	I	CD mechanical switch A/D converter input.
24	I-MIC	I	Microphone input for AUTO VF display.
25	$\overline{\text{I-TU-SIG/MS}}$	I	Tuner signal and deck music sensor signal input.
26	I-SPEANA	I	A/D input for spectrum analyzer display.
27	I-WRQ/RDS-CLK	I	CD WRQ input . TUNER RDS CLOCK input.
28	I-TM-BASE	I	REFERENCE CLOCK input for timer watch.
29	$\overline{\text{I-RMC}}$	I	System remote control signal input.
30~37	G9~G2	O	FL GRID output G2~G9.
38~43	P32~P27	O	FL SEGMENT output P27~P32.
44	G1	O	FL grid output G1.
45	P26	-	FL SEGMENT output P26.
46	VDD3	-	Power supply input.
47	SPEANA-A/P25	O	Spectrum analyzer band switching output /FL segment P25 output.
48	SPEANA-B/P24	O	Spectrum analyzer band switching output /FL segment P24 output.
49	SPEANA-C/P23	O	Spectrum analyzer band switching output /FL segment P23 output.
50	P22/H-DUBB INH	I/O	FL segment P22 output / high dubbing inhibit input to diode.
51	VP	-	Power supply input for FL display.
52	P21/AM-ST	I/O	FL segment P21 output / AM stereo input to diode.
53	P20/LW	I/O	FL segment P20 output / LW mode data input to diode.
54	P19/SW	I/O	FL segment P19 output / SW mode data input to diode.

Pin No.	Pin Name	I/O	Description
55	P18/FM 1	I/O	FL segment P18 output / FM1 (OIRT) data input to diode.
56	P17/RDS	I/O	FL segment P17 output / RDS data input to diode.
57	P16/BBE	I/O	FL segment P16 output / BBE data input to diode.
58	P15/DSP	I/O	FL segment P15 output / DSP data input to diode.
59	P14/DOLBY-SURR	I/O	FL segment P14 output / DOLBY-SURR data input to diode.
60	P13/K-CON	I/O	FL segment P13 output / K-CON data input to diode.
61	P12/DOLBY	I/O	FL segment P12 output / DOLBY data input to diode.
62	P11/WAY	I/O	FL segment P11 output / DECK/WAY MECHA data input to diode.
63	P10/AM-9K/10K	I/O	FL segment P10 output / INITIAL AM 10 kHz step data input to diode.
64	P9/CST 2	I/O	FL segment P9 output / DECK2 cassette detect switch data input.
65	P8/REB	I/O	FL segment P8 output / DECK2 side-B record OK switch data input.
66	P7/CAM 2	I/O	FL segment P7 output / DECK2 CAM switch data input.
67	P6/AUTO 1	I/O	FL segment P6 output / DECK1 AUTO stop signal input.
68	P5/AUTO 2	I/O	FL segment P5 output / DECK2 AUTO stop signal input.
69	P4/CAM 1	I/O	FL segment P4 output / DECK1 CAM switch data input.
70	P3/CST 1	I/O	FL segment P3 output / DECK1 cassette detect switch data input.
71	P2/REA	I/O	FL segment P2 output / DECK2 side A record OK switch data input.
72	VDD 4	-	Power supply input.
73	P1/2092	I/O	FL segment P1 output / SHIFT resistor IC 2092 data input to diode.
74	K-SCAN	O	Switch SCAN timing output.
75	L CK	O	Latch clock output for front shift resistor.
76	PRO-CE	O	PRO LOGIC IC chip enable output.
77	PLL-CE	O	PLL IC chip enable output.
78	MA-STB	O	Latch strobe output for MAIN PWB.
79	DATA	O	DATA output for MAIN, FORNT, PROLOGIC PWB.
80	CLK	O	CLOCK output for MAIN, FORNT, PROLOGIC PWB.
81	DISH-RVS	O	CD turntable reverse rotation output.
82	DISH-FWD	O	CD turntable forward rotation output.
83	TRAY-OPEN	O	CD TRAY OPEN data output.
84	TRAY-CLOSE	O	CD TRAY CLOSE data output.
85	$\overline{\text{LED}} \blacktriangleright\blacktriangleright$	O	$\blacktriangleright\blacktriangleright$ LED $\overline{\text{ON/OFF}}$ output.
86	$\overline{\text{LED}} \blacktriangleleft\blacktriangleleft$	O	$\blacktriangleleft\blacktriangleleft$ LED $\overline{\text{ON/OFF}}$ output.
87	$\overline{\text{LED}} \blacktriangleright$	O	\blacktriangleright LED $\overline{\text{ON/OFF}}$ output.
88	$\overline{\text{LED}} \blacktriangleleft$	O	\blacktriangleleft LED $\overline{\text{ON/OFF}}$ output.
89	VSS 2	-	GND.
90	VDD 2	-	Power supply input.
91	$\overline{\text{LED}} \blacksquare$	O	\blacksquare LED $\overline{\text{ON/OFF}}$ output.
92	$\overline{\text{LED}} \parallel$	O	\parallel LED $\overline{\text{ON/OFF}}$ output.
93	SOL 1	O	DECK 1 Solenoid output.
94	SOL 2	O	DECK 2 Solenoid output.
95	O-MOTOR	O	DECK MOTOR $\overline{\text{ON/OFF}}$ output.
96	I-IFC/I-SUB Q	I	Tune IF count serial data input /CD SUB Q data input.

Pin No.	Pin Name	I/O	Description
97	I-STEREO/O-SQCLK	I/O	Tuner stereo detected input/CD SQ CLOCK output.
98	I-RDS-DATA/O-DATA	I/O	RDS data input/CD data output.
99	O-CD CE	O	CD CE output.
100	O-CD CLK	O	CD CLOCK output.

IC, LC72131

Pin No.	Pin Name	I/O	Description																								
1	XIN	I/O	A crystal oscillator (7.2MHz) is connected between these pins.																								
22	XOUT																										
2	NC	-	Not used.																								
3	CE	I	To enable the IC. Active "H".																								
4	DI	I	Digital data input from CPU (LC866548V-5E15) when relevant key is operated. Active "H".																								
5	CLK	I	To clock in the data DI.																								
6	DO	O	Digital data output to CPU (LC866548V-5E15).																								
7	TM-BASE	O	Outputs a reference clock signal (8Hz) for the clock.																								
8	MONO / BEAT	O	Outputs "H" when MONO / BEAT is switched.																								
9	FM / AM	O	Output "L" or "H" as follows: <table border="1" style="margin-left: 20px;"> <thead> <tr> <th colspan="2">2 BAND</th> <th colspan="3">3 BAND</th> <th colspan="3">3 BAND</th> </tr> <tr> <th>AM</th> <th>FM</th> <th>LW</th> <th>MW</th> <th>FM</th> <th>MW</th> <th>SW</th> <th>FM</th> </tr> </thead> <tbody> <tr> <td>H</td> <td>L</td> <td>H</td> <td>H</td> <td>L</td> <td>H</td> <td>L</td> <td>L</td> </tr> </tbody> </table>	2 BAND		3 BAND			3 BAND			AM	FM	LW	MW	FM	MW	SW	FM	H	L	H	H	L	H	L	L
2 BAND		3 BAND			3 BAND																						
AM	FM	LW	MW	FM	MW	SW	FM																				
H	L	H	H	L	H	L	L																				
10	MW	O	Outputs "L" or "H" as follows: <table border="1" style="margin-left: 20px;"> <thead> <tr> <th colspan="2">2 BAND</th> <th colspan="3">3 BAND</th> <th colspan="3">3 BAND</th> </tr> <tr> <th>AM</th> <th>FM</th> <th>LW</th> <th>MW</th> <th>FM</th> <th>MW</th> <th>SW</th> <th>FM</th> </tr> </thead> <tbody> <tr> <td>L</td> <td>L</td> <td>H</td> <td>L</td> <td>L</td> <td>L</td> <td>H</td> <td>L</td> </tr> </tbody> </table>	2 BAND		3 BAND			3 BAND			AM	FM	LW	MW	FM	MW	SW	FM	L	L	H	L	L	L	H	L
2 BAND		3 BAND			3 BAND																						
AM	FM	LW	MW	FM	MW	SW	FM																				
L	L	H	L	L	L	H	L																				
11	IF-MUTE	O	To control internal counter.																								
12	IFIN	I	General purpose counter input.																								
13	TUNE	I	Receives "L" when station is tuned.																								
14	NC	-	Not used.																								
15	A MIN	I	Receives the AM local oscillator frequency signal.																								
16	F MIN	I	Receives the FM local oscillator frequency signal.																								
17	VDD	-	Supply power to IC (+5V).																								
18	PD	O	PLL charge pump output.																								
19	AIN	I	The MOS transistor for PLL active low pass filter.																								
20	AOUT	O																									
21	VSS	-	Ground.																								

ADJUSTMENT - 1 <TUNER / DECK>

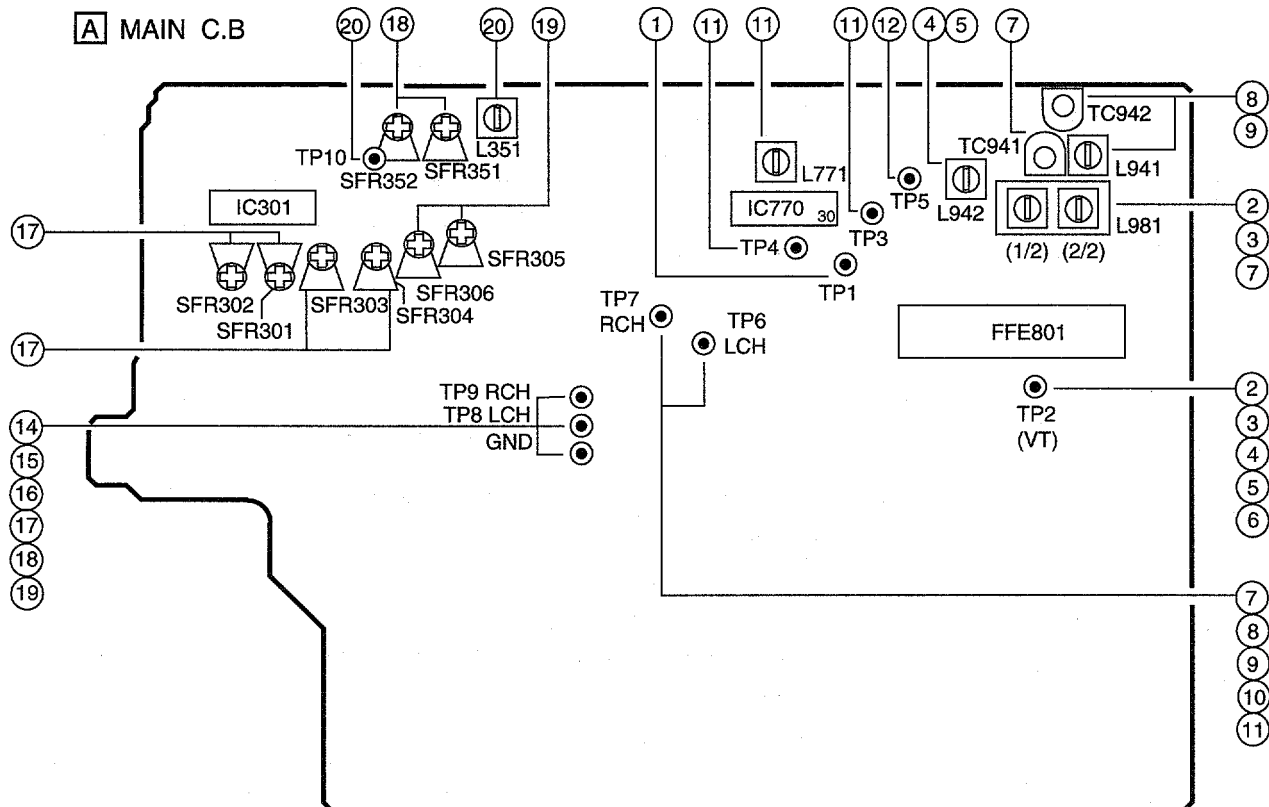

J DECK C.B

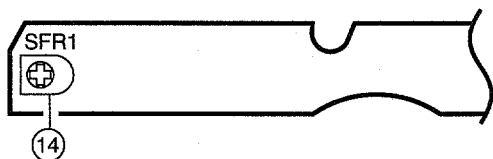

DECK-1 P, DECK-2 R / P / E HEAD

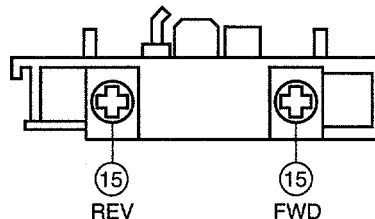

< TUNER SECTION >

1. Clock Frequency Check
 Settings : • Test point : TP1 (CLK IC770 pin30)
 Method : Set to MW 1710kHz (HR), 1602kHz (EZ,K,V), and check that the test point is 2160kHz \pm 45Hz (HR), 2052 \pm 0.045kHz (EZ,K,V).
2. MW VT Adjustment
 Settings : • Test point : TP2 (VT)
 • Adjustment location : L981 (1/2)
 Method : Set to MW 1710kHz (HR), 531kHz (EZ,K,V) and adjust L981 (1/2) so that the test point is 8.5V \pm 0.05V (HR), 1.5V \pm 0.05V(EZ,K,V).
3. MW VT Check
 Settings : • Test point : TP2 (VT)
 Method : Set to MW 530kHz (HR), 1602kHz (EZ,K,V) and check that the test point is more than 0.3 (HR), less than 8.5 (EZ,K,V).
4. SW VT Adjustment <HR>
 Settings : • Test point : TP2 (VT)
 • Adjustment location : L942
 Method : Set to SW 17.9MHz and adjust L942 so that the test point is 7.0V \pm 0.05V.
5. LW VT Adjustment <EZ,K,V>
 Settings : • Test point : TP2 (VT)
 • Adjustment location : L942
 Method : Set to LW 144kHz and adjust L942 so that the test point is 1.3V \pm 0.05V.
6. FM VT Check (HR)
 Settings : • Test point : TP2 (VT)
 Method : Set to FM 87.5MHz, 108.0MHz and check that the test point is more than 1.5V (87.5MHz) and less than 8.5V (108.0MHz).
7. MW Tracking Adjustment <HR>
 Settings : • Test point : TP6,TP7
 • Adjustment location :
 L981 (2/2) 600kHz
 TC941 1400kHz
 Method : Set up TC941 to center before adjustment, the level at 600kHz is adjust to maximum by L981 (2/2). Then the level at 1400kHz is adjust to maximum by TC941.

8. SW Tracking Adjustment <HR>
 Settings : • Test point : TP6,TP7
 • Adjustment location :
 L941 5.9MHz
 TC942 17.9MHz
 Method : Set up TC942 to center before adjustment. The level at 5.9MHz is adjust to maximum by L941. Then the level at 17.9MHz is adjust to maximum by TC942.

9. LW Tracking Adjustment <EZ,K,V>
 Settings : • Test point : TP6, TP7
 • Adjustment location :
 L941 144kHz
 TC942 290kHz
 Method : Set up TC942 to center before adjustment. The level at 144kHz is adjust to maximum by L941. Then the level at 290kHz is adjust to maximum by TC942.

10. FM Tracking Check
 Settings : • Test point : TP6, TP7
 Method : Set to FM 98.0MHz (HR,EZ,K,V), 70MHz (V), 98MHz (V), and check that the test point is 2 ± 6 dB (HR), 6 ± 6 dB (EZ,K), 2 ± 6 dB (V), 6 ± 5 dB (70MHz (V)).

11. DC Balance / Mono Distortion Adjustment
 Settings : • Test point : TP3, TP4 (DC Balance)
 : TP6, TP7 (Distortion)
 • Adjustment location : L771
 • Input level : 54dB
 Method : Set to FM 98.0MHz and adjust L771 so that the voltage between TP3 and TP4 becomes $0V \pm 0.04V$. Next, check that the distortion is less than 1.3%.

12. Auto Stop Level Check
 Settings : • Test point : TP5
 • Input level : Variable
 Method : Set to FM 98.0MHz and check voltage low (about 0.1V). After that voltage high (about 7.0V) by 2dB down and the level is 25 ± 10 dB.

13. Auto Stop Level Check

SW

- Input level : Variable
 Method : Check auto stop at SW 12MHz and the level is less than 60dB.

MW

- Input level : Variable
 Method : Check auto stop at MW 999kHz and the level is $50 +10/-15$ dB.

FM

- Input level : Variable
 Method : Check auto stop at FM 98.0MHz and the level is $25 \text{ dB} \pm 10 \text{ dB}$.

< DECK SECTION >

14. Tape Speed Adjustment
 Settings : • Test tape : TTA-100
 • Test point : TP8, TP9
 • Adjustment location : SFR1
 Method : Play back the test tape and adjust SFR1 so that the frequency counter reads $3000\text{Hz} \pm 5\text{Hz}$.

15. Head Azimuth Adjustment
 Settings : • Test tape : TTA-300
 • Test point : TP8, TP9
 • Adjustment location : Head azimuth adjustment screw
 Method : Play back the 10kHz signal of the test tape and adjust screw so that the output becomes maximum.

16. PB Frequency Response Check (DECK 1, DECK 2)
 Settings : • Test tape : TTA-300
 • Test point : TP8, TP9
 Method : Play back the 315Hz and 10kHz signals of the test tape and check that the output ratio of the 10kHz signal with respect to that of the 315Hz signal is ± 2 dB.

17. PB Sensitivity Adjustment (DECK 1, DECK 2)
 Settings : • Test tape : TTA-200
 • Test point : TP8, TP9
 • Adjustment location : SFR301 (DECK 1, Lch)
 SFR302 (DECK 1, Rch)
 SFR303 (DECK 2, Lch)
 SFR304 (DECK 2, Rch)
 Method : Play back the test tape and adjust SFRs so that the output level of the test point becomes 245mV.

18. REC/PB Frequency Response Adjustment
 Settings : • Test tape : TTA-602
 • Test point : TP8, TP9
 • Input signal : 1kHz / 10kHz (LINE IN)
 • Adjustment location : SFR351 (Lch)
 SFR352 (Rch)
 Method : Apply a 1kHz signal and REC mode. Then adjust OSC attenuator so that the output level at the TP8, TP9 becomes 17mV. Record and play back the 1kHz and 10kHz signals and adjust SFRs so that the output of the 10kHz signals becomes $0\text{dB} \pm 0.5\text{dB}$ with respect to that of the 1kHz signal.

19. REC/PB Sensitivity Adjustment
 Settings : • Test tape : TTA-602
 • Test point : TP8, TP9
 • Input signal : 1kHz (LINE IN)
 • Adjustment location : SFR305 (Lch)
 SFR306 (Rch)
 Method : Apply a 1kHz signal and REC mode. Then adjust OSC attenuator so that the output level at the TP8, TP9 becomes 17mV. Record and play back the 1kHz signals and adjust SFRs so that the output becomes $17\text{mV} \pm 0.5\text{dB}$.

20. Bias OSC Frequency Adjustment
 Settings : • Test tape : TTA-615
 • Test point : TP10
 • Adjustment location : L351
 Method : Set to the REC mode. Adjust L351 so that the frequency at the test point is $85\text{kHz} \pm 1\text{kHz}$.

PRACTICAL SERVICE FIGURE

<TUNER SECTION>

<FM SECTION>

IHF Sensitivity : 4dB ± 6dB (74HR)
 (THD 3%) [at 87.5 / 98.0 / 108.0MHz (74HR)]
 Less than 10dB (70EZ,K,V)
 [at 87.5 / 98.0 / 108.0MHz (70EZ,K,V)]

S/N 50dB Quieting sensitivity :
 30dB ± 6dB (74HR)
 [at 87.5 / 98.0 / 108.0MHz (74HR)]
 Less than 38dB (70EZ,K,V)
 [at 87.5 / 98.0 / 108.0MHz (70EZ,K,V)]

Signal to noise ratio : Mono : More than 65dB
 Stereo : More than 64dB
 [at 98.0MHz]

Distortion : Mono : Less than 1.3%
 Stereo : Less than 2.0%
 [at 98.0MHz]

Auto stop level : 25dB ± 10dB [at 98.0MHz]

Stereo separation : 74HR : More than 25dB [at 98.0MHz]
 70EZ,K,V : More than 22dB [at 98.0MHz]

Intermediate frequency : 10.7MHz

<MW SECTION>

Sensitivity : 50 ~ 60dB
 (S/N 20 dB) [at 603kHz]
 48 ~ 58dB
 [at 999kHz]
 48 ~ 58dB
 [at 1404kHz]

Signal to noise ratio : More than 36dB
 [at 999kHz]

Distortion : Less than 1.5%
 [at 999kHz]

Auto stop level : 50dB +10/-15dB
 [at 999kHz]

Intermediate frequency : 450kHz

<LW SECTION> (70EZ,K,V)

Sensitivity : 61 ~ 71dB
 (S/N 20 dB) [at 144kHz]
 58 ~ 68dB
 [at 198kHz]
 58 ~ 68dB
 [at 290kHz]

Signal to noise ratio : More than 36dB
 [at 198kHz]

Distortion : Less than 1.2%
 [at 198kHz]

Auto stop level : 66dB +10/-15dB
 [at 198kHz]

Intermediate frequency : 450kHz

<SW SECTION> (74HR)

Sensitivity : 38 ± 5dB
 (S/N 20 dB) [at 5.9MHz]
 33 ± 5dB
 [at 12.0 MHz]
 30 ± 5dB
 [at 17.9MHz]

Signal to noise ratio : More than 36dB
 [at 12.0MHz]

Distortion : Less than 2.0%
 [at 12.0MHz]

Intermediate frequency : 450kHz

<DECK SECTION>

Tape speed : 3000Hz ± 45Hz

Wow & flutter : Less than 0.15%
 (W.R.M.S)

Take-up torque : 30 ~ 55g-cm
 (FWD, REV)

F.F & REW torque : 75 ~ 180g-cm

Back tension : 2 ~ 7g-cm
 (FWD, REV)

PB output level : 300mV ± 1dB
 (SP OUT 2V)

REC/PB output level : 180mV ± 2dB
 (SP OUT 2V)

Distortion (REC/PB) : Less than 2.0%
 (NORM, CrO₂)

Noise level (REC/PB) : Less than 1.8mV
 (NORM, SP OUT 2V, DOLBY OFF)
 Less than 1.1mV
 (CrO₂, SP OUT 2V, DOLBY B,C ON)

Crosstalk : More than 60dB
 (1kHz, 0VU)

Channel separation : More than 30dB
 (1kHz, 0VU)

Erasing ratio : More than 30dB
 (at 125Hz)

Test tape : TTA-602 (NORMAL)
 TTA-615 (CrO₂)

TAPE MECHANISM EXPLODED VIEW 1 / 1

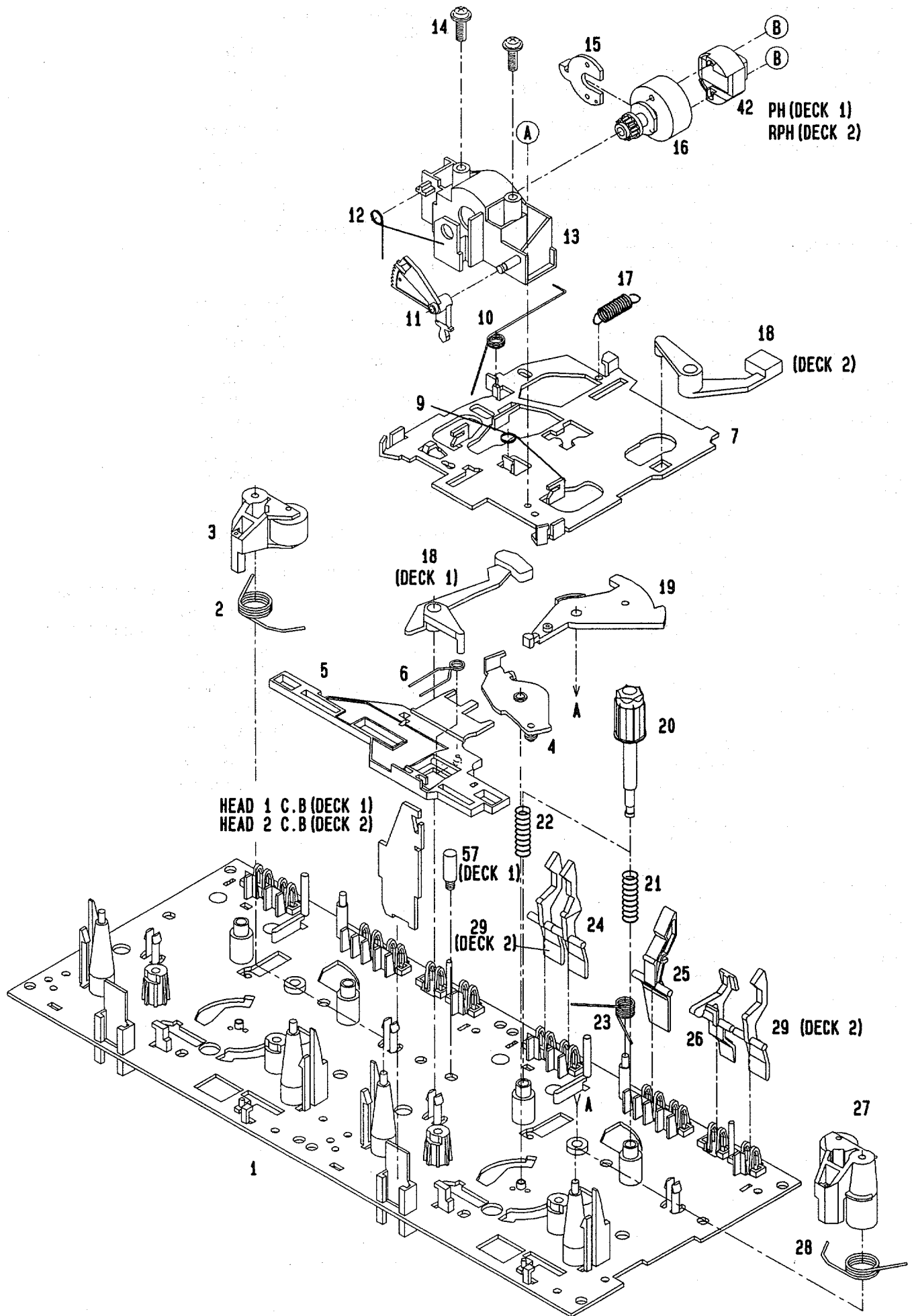

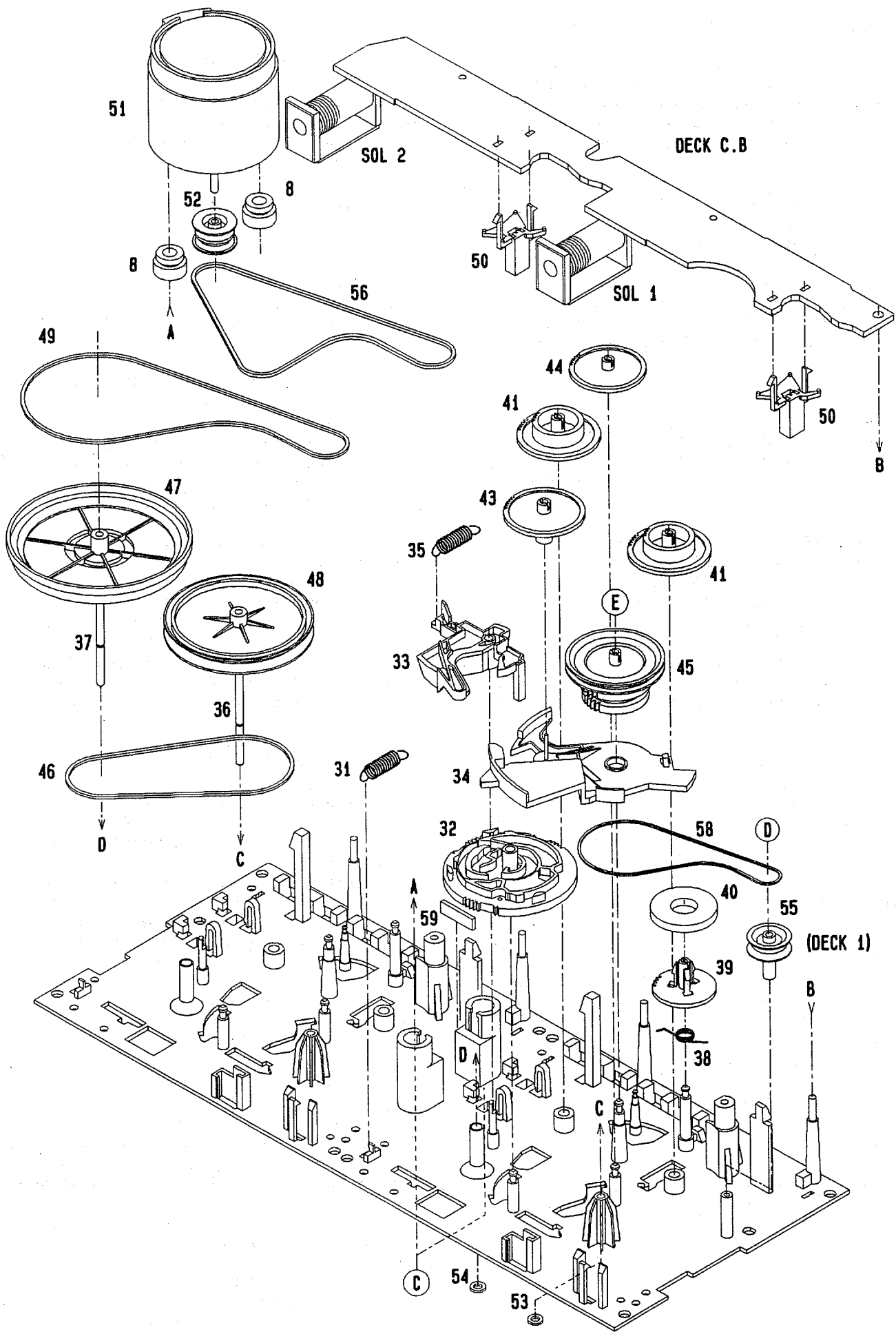

TAPE MECHANISM PARTS LIST 1 / 1

If can't understand for Description please kindly refer to "REFERENCE NAME LIST".

REF. NO.	PART NO.	KANRI NO.	DESCRIPTION	REF. NO.	PART NO.	KANRI NO.	DESCRIPTION
1	82-ZM3-301-519		CHAS ASSY,M2	36	82-ZM1-236-019		CAPSTAN N 2-41.5
2	82-ZM1-258-110		SPR-T,PINCH L	37	82-ZM1-239-019		CAPSTAN N 2.2-41.7
3	82-ZM1-341-110		LVR ASSY,PINCH L2	38	82-ZM1-322-019		SPR-T,FR60
4	82-ZM1-333-010		PLATE,LINK 2	39	82-ZM1-220-219		GEAR,IDLER
5	82-ZM1-266-11K		LVR,DIR	40	82-ZM3-616-019		RING MAGNET 4
6	82-ZM1-214-010		SPR-T,DIR	41	82-ZM1-216-31K		GEAR,REEL
7	82-ZM1-206-81K		CHAS,HEAD	42	87-A90-319-010		HEAD,PH HADKH2 FPC
8	82-ZM3-307-019		CUSH-G,DIA3.7-8-3.2	42	87-A90-320-010		HEAD,RPH HADKH5 FPC
9	82-ZM1-269-219		SPR-T,BRG	43	82-ZM1-225-21K		GEAR,FR
10	82-ZM1-219-119		SPR-T,LINK	44	82-ZM1-226-019		GEAR,REW
11	82-ZM1-210-119		GEAR,H T	45	82-ZM3-333-310		SLIP DISK ASSY 2
12	82-ZM1-213-019		SPR-T,HEAD	46	82-ZM1-338-010		BELT FR4
13	82-ZM1-207-619		GUIDE,TAPE	47	82-ZM1-349-110		FLY-WHL,R W(DECK 2)
14	86-ZM4-206-010		S-SCREW,AZIMUTH	47	82-ZM3-338-110		FLY-WHL,R3 W(DECK 1)
15	82-ZM1-314-119		PLATE,HEAD	48	82-ZM1-348-010		FLY-WHL,L W(DECK 2)
16	82-ZM1-208-119		HLDR,HEAD	48	82-ZM1-348-010		FLY-WHL,L W(DECK 1)
17	82-ZM1-218-019		SPR-E,HB	49	82-ZM3-329-210		BELT,SBU R2
18	82-ZM1-263-110		LVR,EJECT L (DECK 1)	50	82-ZM1-245-210		HLDR,IC
18	82-ZM1-264-010		LVR,EJECT R (DECK 2)	51	87-045-347-019		MOT,SHU2L 70(M1)
19	82-ZM1-222-21K		LVR,PLAY	52	82-ZM3-221-010		PULLEY,MOT 2M
20	82-ZM1-217-319		REEL TABLE	53	82-ZM1-288-019		SH,1.63-3.2-0.5 SLT
21	82-ZM1-244-510		SPR-C,BT	54	80-ZM6-243-019		SH,1.75-3.6-0.5 SLT
22	82-ZM1-285-310		SPR-C,BT L	55	82-ZM3-335-210		PULLEY,COUPLER M3(DECK 1)
23	82-ZM1-257-019		SPR-T,CAS	56	82-ZM3-337-010		BELT,SBU MOT 2
24	82-ZM1-241-319		LVR,MC	57	82-ZM3-339-010		SHAFT,COUPLER N3(DECK 1)
25	82-ZM1-242-019		LVR,CAS	58	86-ZM1-206-010		BELT,MAIN L
26	82-ZM1-243-019		LVR,STOP	59	82-ZM3-340-010		SH,BELT D2
27	82-ZM1-344-110		LVR ASSY,PINCH R2	A	85-ZM3-202-010		S-SCREW,TG
28	82-ZM1-259-110		SPR-T,PINCH R	B	80-ZM6-207-019		V+1.6-7
29	82-ZM1-240-11K		LVR,REC (DECK 2)	C	82-ZM3-318-019		S-SCRW MOTOR M2
31	82-ZM1-255-319		SPR-E,LVR DIR	D	87-B10-043-010		W-P,0.99-4-0.25 SLT
32	82-ZM3-305-01K		GEAR,CAM M2	E	82-ZM3-334-010		PW,2.16-6-0.4
33	82-ZM1-227-21K		LVR,TRIG				
34	82-ZM3-306-11K		LVR,FR M2				
35	82-ZM1-265-119		SPR-E,TRIG				

SPRING APPLICATION POSITION

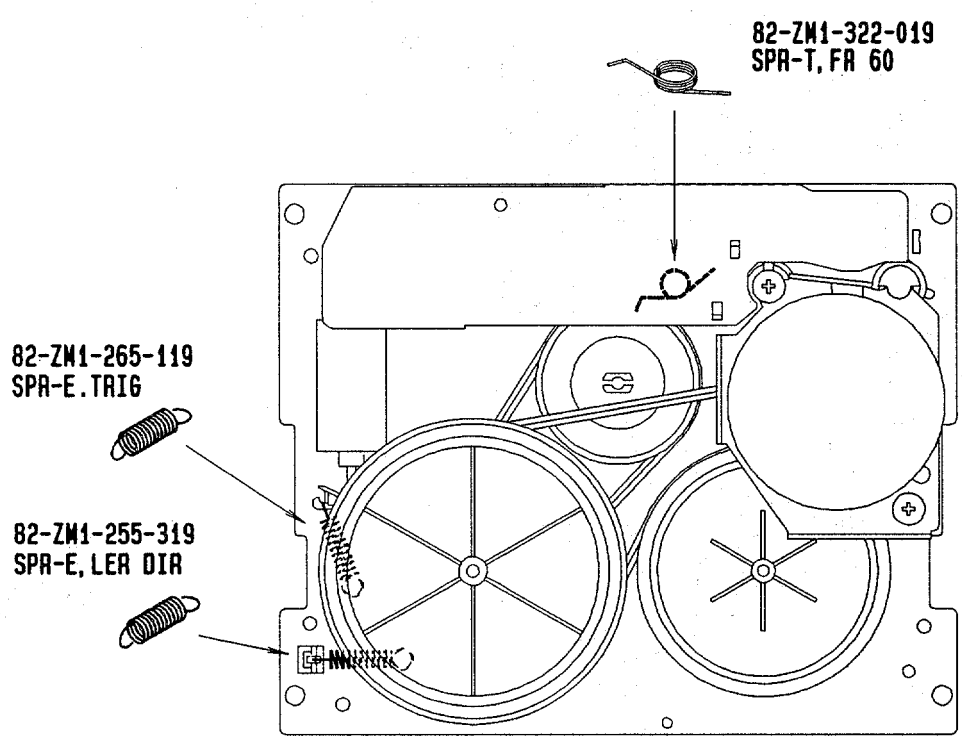
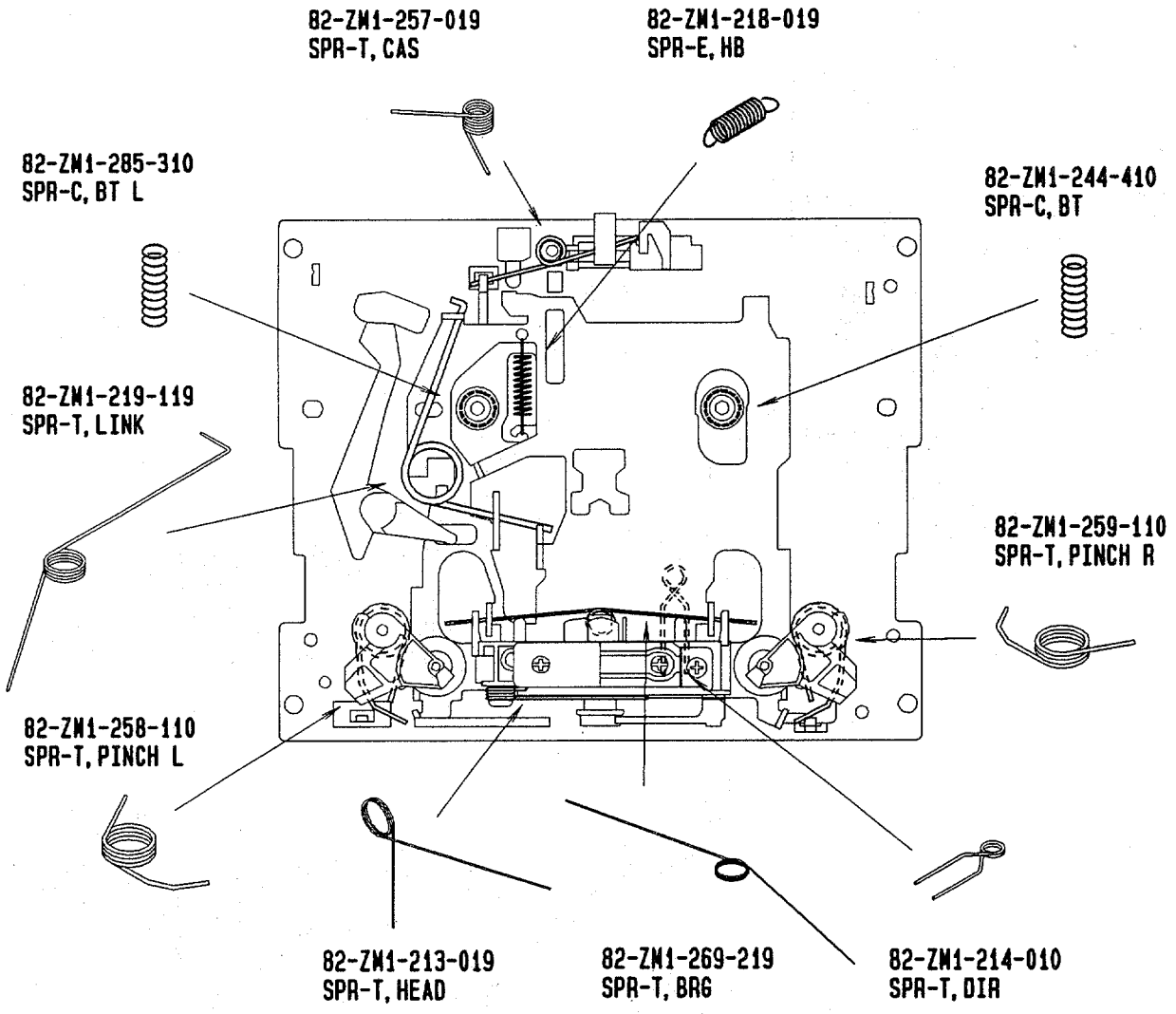

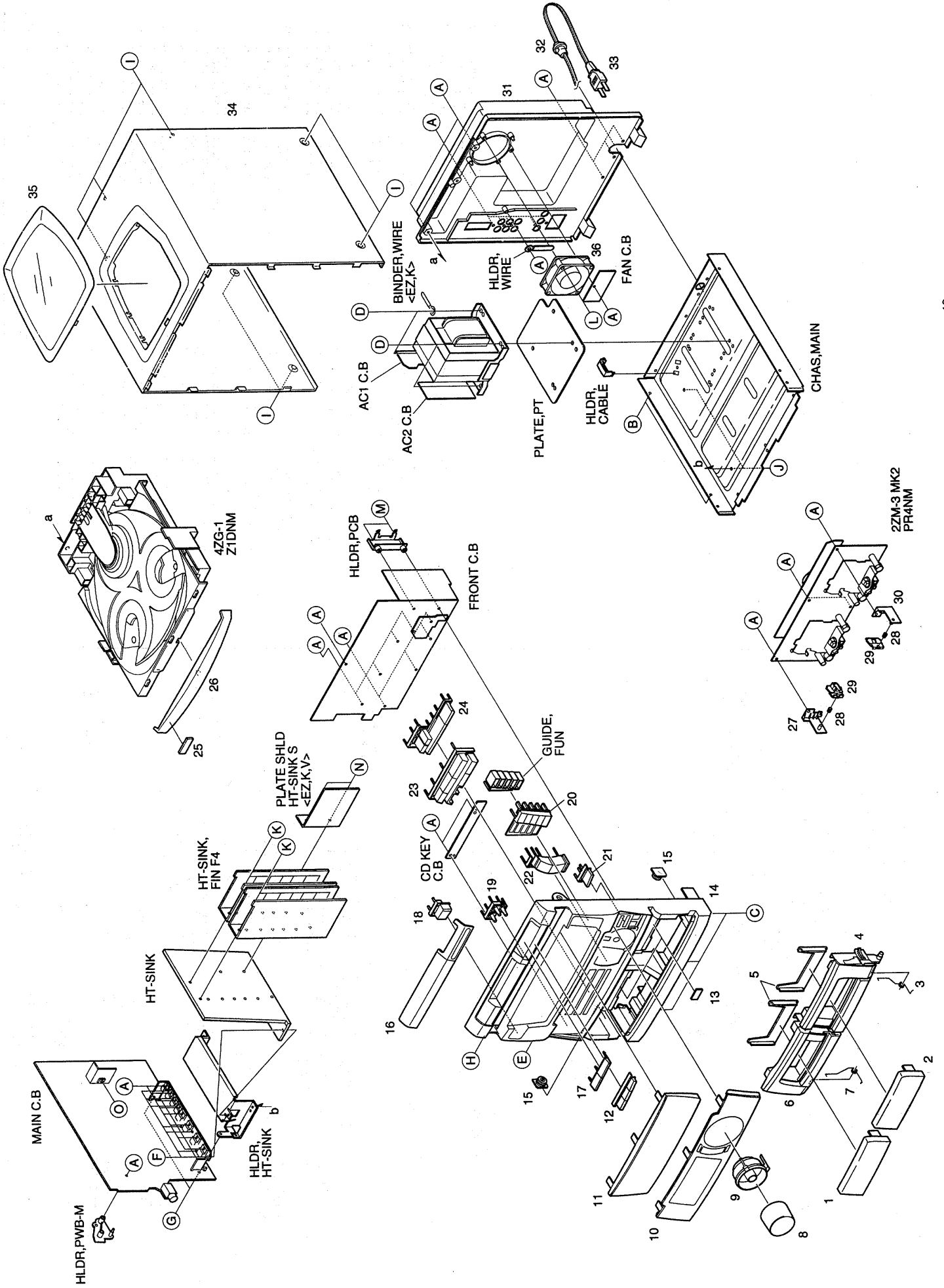

MECHANICAL PARTS LIST 1 / 1

If can't understand for Description please kindly refer to "REFERENCE NAME LIST".

REF. NO.	PART NO.	KANRI NO.	DESCRIPTION	REF. NO.	PART NO.	KANRI NO.	DESCRIPTION
1	87-NF5-010-010		WINDOW, CASS 1	28	82-NF5-228-010		SPR-C, LOCK
2	87-NF5-011-010		WINDOW, CASS 2	29	82-NF5-229-010		PLATE, LOCK
3	82-NF5-219-010		SPR-T, EJECT 2(SIN)	30	87-NF4-217-010		HLD, LOCK 2
4	87-NF5-004-010		BOX, CASS 2H	31	87-NF5-033-010		CABI, REAR EZSTNE<70EZ>
5	86-NF6-061-010		REFLECTOR, CASS	31	87-NF5-036-010		CABI, REAR HRJSTNM<74HR>
6	87-NF5-003-010		BOX, CASS 1H	31	87-NF5-034-010		CABI, REAR KSTNE<70K>
7	82-NF5-218-010		SPR-T, EJECT 1(SIN)	31	87-NF5-038-010		CABI, REAR VSTNM<70V>
8	87-NF5-023-010		KNOB, RTRY VOL	32	87-085-185-010		BUSHING, AC CORD(E) CM-22B
9	87-NF5-007-010		RING, VOL	33	87-050-016-010		AC CORD ASSY, E<70EZ>
10	87-NF5-002-010		PANEL, FR H	33	87-050-079-010		AC CORD ASSY, E BLK<74HR, 70V>
11	87-NF5-048-010		WINDOW, DISP E<70EZ>	33	87-A80-023-010		AC CORD ASSY, K 3P W<70K>
11	87-NF5-009-010		WINDOW, DISP H<EXCEPT 70EZ>	34	86-NFT-005-110		CABI, STEEL TS
12	87-NF5-016-010		KEY, DISC	35	86-NF6-007-010		WINDOW, TOP
13	81-532-080-010		LBL, CASS-COMPT	36	87-A90-463-010		FAN, 2408NL<74HR>
14	87-NF5-001-010		CABI, FR H<EXCEPT 74HR>	A	87-067-703-010		BVT2+3-10 W/O SLOT
14	87-NF5-042-010		CABI, FR H S74<74HR>	B	87-591-094-410		QIT+3-6
15	87-063-165-010		OIL-DMPR, 150	C	87-067-688-010		BVTT+3-6
16	87-NF5-008-010		WINDOW, CD	D	87-067-975-010		S-SCREW, IT+4-8 SWCH12A
17	87-NF5-015-010		KEY, OPEN	E	87-721-096-410		QT2+3-10 W/O SLOT
18	87-NF5-017-010		KEY, POWER	F	87-067-758-010		BVT2+3-12 W/O SLOT
19	87-NF5-019-010		KEY, DEMO	G	87-067-633-010		BVT2+3-8 W/O SLOT W/CONVEX
20	87-NF5-018-010		KEY, FUN	H	87-721-097-410		QT2+3-12 W/O SLOT
21	87-NF5-020-010		KEY, VF	I	87-067-641-010		UTT2+3-8 W/O SLOT BLK
22	87-NF5-022-010		KEY, GEQ	J	87-067-584-010		BVT2+3-6 W/O SLOT
23	87-NF5-024-010		KEY, ASSY OPE	K	87-067-690-010		BVIT3B+3-12 BLK
24	87-NF5-021-010		KEY, EDIT<EXCEPT 70EZ>	L	87-571-104-410		VIT+3-30<74HR>
24	87-NF5-052-010		KEY, RDS<70EZ>	M	87-067-581-010		BVT2+3-15 W/O SLOT
25	82-NE6-067-010		BADGE, ATWA 30N	N	87-B10-090-010		BVIT3B+3-12 GOLD<EXCEPT 74HR>
26	87-NF5-005-010		PANEL, TRAY H	O	87-067-579-010		BVT2+3-8 W/O SLOT
27	87-NF4-216-010		HLD, LOCK 1				

ACCESSORIES / PACKAGE LIST

If can't understand for Description please kindly refer to "REFERENCE NAME LIST".

REF. NO.	PART NO.	KANRI NO.	DESCRIPTION
1	87-NF5-901-010		IB, H(ECA)M<74HR>
1	87-NF5-905-010		IB, K(E)E<70K>
1	87-NF5-906-010		IB, E(EGFSI)E<70EZ>
1	87-NF5-907-010		IB, V(ERHPCH)M<70V>
2	87-NB7-651-010		RC UNIT, RC-7AS08
3	87-A90-064-010		FEEDER-ANT, FM (SHS)<70V, 74HR>
3	87-043-106-010		ANT, FM 1007 AWG<70EZ, K>
4	87-A90-312-010		PLUG, CONVERSION WTN-1157R1<74HR>
5	87-006-225-010		ANT, LOOP ANT NC2<70EZ, K, V>
5	87-A90-054-010		ANT, LOOP AM-CON C<74HR>
6	87-043-095-010		ANT, WIRE<74HR>

SPEAKER DISASSEMBLY INSTRUCTIONS

Type.1

矢印の位置にマイナスドライバーを差し込んで、パネルを外します。各々のスピーカーユニットのビスを取り、スピーカーユニットを外してください。

Insert a flat-bladed screwdriver into the position indicated by the arrows and remove the panel. Remove the screws of each speaker unit and then remove the speaker units.

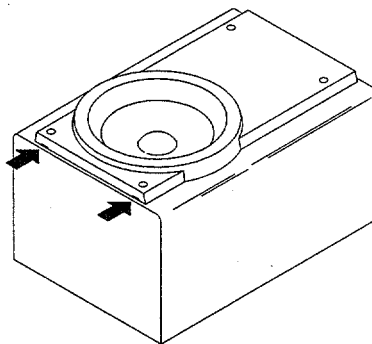

Type.2

グリルフレームを外し、4個のゴムキャップをマイナスドライバーで端の方から持ち上げて外すと中にビスが有りますので、ビスを取り外します。矢印の位置にマイナスドライバーを差し込んで、パネルを外します。各々のスピーカーユニットのビスを取り、スピーカーユニットを外してください。

Remove the grill frame and four pieces of rubber caps by pulling out with a flat-bladed screwdriver. Remove the screws from hole where installed rubber caps. Insert a flat-bladed screwdriver into the position indicated by the arrows and remove the panel. Remove the screws of each speaker unit and then remove the speaker units.

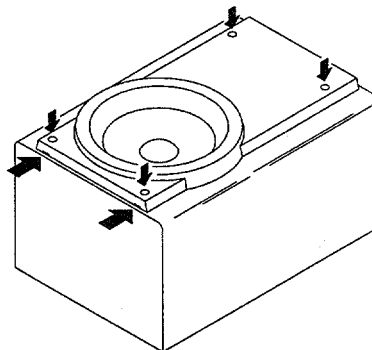

Type.3

矢印の位置にマイナスドライバーを差し込んで、パネルを外します。各々のスピーカーユニットの凹にマイナスドライバーを差し込んで、反時計方向に回転させスピーカーユニットを外してください。スピーカーユニット交換後は時計方向にクリック音がするまで、回転させて取り付けます。

Insert a flat-bladed screwdriver into the position indicated by the arrows and remove the panel. Turn the speaker unit to counter-clockwise direction while inserting a flat-bladed screwdriver into one of the hollows around speaker unit, and then remove the speaker unit. After replacing the speaker unit, install it turning to clockwise direction until "click" sound comes out.

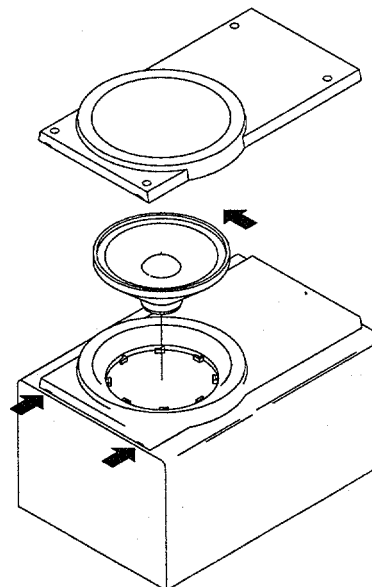

**SX-ANS70 (YJ,YL,Y,YJ1,YJ7,Y1)
SPEAKER PARTS LIST**

If can't understand for Description please kindly refer to "REFERENCE NAME LIST".

REF. NO.	PART NO.	KANRI NO.	DESCRIPTION
1	87-NS5-001-010		PANEL, FR R
2	87-NS5-002-010		PANEL, FR L
3	87-NS5-010-010		PROTECTOR, R
4	87-NS5-011-010		PROTECTOR, L
5	87-NS5-012-010		PROTECTOR, TOP
6	87-NS5-025-010		GRILLE, FRAME ASSY R
7	87-NS5-026-010		GRILLE, FRAME ASSY L
8	87-NS4-611-019		SPKR, CORD
9	85-NS6-611-019		SPKR, CORD Y/B
10	87-NS5-602-019		SPKR, W 160
11	87-NS5-604-019		SPKR, MID
12	87-NS5-605-019		SPKR, T 50

**SX-NS74 (YJ,YL,YJ7)
SPEAKER PARTS LIST**

If can't understand for Description please kindly refer to "REFERENCE NAME LIST".

REF. NO.	PART NO.	KANRI NO.	DESCRIPTION
1	87-NSE-001-010		PANEL, FR R
2	87-NSE-002-010		PANEL, FR L
3	87-NSF-003-010		PANEL, DUCT R
4	87-NSF-004-010		PANEL, DUCT L
5	87-NSE-012-010		GRILLE, FRAME ASSY R
6	87-NSE-014-010		GRILLE, FRAME ASSY L
7	87-NSE-602-019		SPKR, W 160
8	87-NSE-604-019		SPKR, T 80
9	87-NSF-610-019		SPKR, CORD

**SX-R240 (YB,YJB,YUB,YUST,YJST,YST,YUAST)
SPEAKER PARTS LIST**

If can't understand for Description please kindly refer to "REFERENCE NAME LIST".

REF. NO.	PART NO.	KANRI NO.	DESCRIPTION
1	85-NSV-001-010		PANEL, FR<YB, YJB, YUB>
1	86-NSX-009-010		PANEL FR ST<YUST, YJST, YST, YUAST>
2	85-NSX-005-010		GRILLE, FRAME ASSY<EXCEPT YUAST>
2	85-NSX-015-010		GRILLE, FRAME ASSY E<YUAST>
3	85-NSL-601-010		SPEAKER
4	81-VSA-010-010		SPEAKER CORD

REFERENCE NAME LIST

ELECTRICAL SECTION

DESCRIPTION	REFERENCE NAME
ANT	ANTENNAS
C-	CHIP
C-CAP	CAP, CHIP
C-CAP TN	CAP, CHIP TANTALUM
C-COIL	COIL, CHIP
C-DI	DIODE, CHIP
C-DIODE	DIODE, CHIP
C-FET	FET, CHIP
C-FOTR	FILTER, CHIP
C-JACK	JACK, CHIP
C-LED	LED, CHIP
C-RES	RES, CHIP
C-SFR	SFR, CHIP
C-SLIDE SW	SLIDE SWITCH, CHIP
C-SW	SWITCH, CHIP
C-TR	TRANSISTOR, CHIP
C-VR	VOLUME, CHIP
C-ZENER	ZENER, CHIP
CAP, CER	CAP, CERA-SOL
CAP, E	CAP, ELECT
CAP, M/F	CAP, FILM
CAP, TC	CAP, CERA-SOL
CAP, TC-U	CAP, CERA-SOL SS
CAP, TN	CAP, TANTALUM
CERA FIL	FILTER, CERAMIC
CF	FILTER, CERAMIC
DL	DELAY LINE
E/CAP	CAP, ELECT
FILT	FILTER
FLTR	FILTER
FUSE RES	RES, FUSE
MOT	MOTOR
P-DIODE	PHOTO DIODE
P-SNSR	PHOTO SENSER
P-TR	PHOTO TRANSISTOR
POLY VARI	VARIABLE CAPACITOR
PPCAP	CAP, PP
PT	POWER TRANSFORMER
PTR, RES	PTR, MELF
RC	REMOTE CONTROLLER
RES NF	RES, NON-FLAMMABLE
RESO	RESONATOR
SHLD	SHIELD
SOL	SOLENOID
SPKR	SPEAKER
SW, LVR	SWITCH, LEVER
SW, RTRY	SWITCH, ROTARY
SW, SL	SWITCH, SLIDE
TC CAP	CAP, CERA-SOL
THMS	THERMISTOR
TR	TRANSISTOR
TRIMER	CAP, TRIMMER
TUN-CAP	VARIABLE CAPACITOR
VIB, CER	RESONATOR, CERAMIC
VIB, XTAL	RESONATOR, CRYSTAL
VR	VOLUME
ZENER	DIODE, ZENER

MECHANICAL SECTION

DESCRIPTION	REFERENCE NAME
ADHESHIVE	SHEET ADHESHIVE
AZ	AZIMUTH
BAR-ANT	BAR-ANTENNA
BAT	BATTERY
BATT	BATTERY
BRG	BEARING
BTN	BUTTON
CAB	CABINET
CASS	CASSETTE
CHAS	CHASSIS
CLR	COLLAR
CONT	CONTROL
CRSR	CURSOR
CU	CUSHION
CUSH	CUSHION
DIR	DIRECTION
DUBB	DUBBING
FL	FRONT LOADING
FLY-WHL	FLYWHEEL
FR	FRONT
FUN	FUNCTION
G-CU	G-CUSHION
HDL	HANDOL
HIMERON	CLOTH
HINGE, BAT	HINGE, BATTERY
HLDR	HOLDER
HT-SINK	HEAT SINK
IB	INSTRUCTION BOOKLET
IDLE	IDLER
IND, L-R	INDICATOR, L-R
KEY, CONT	KEY, CONTROL
KEY, PRGM	KEY, PROGRAM
KNOB, SL	KNOB, SLIDE
LBL	LABEL
LID, BATT	LID, BATTERY
LID, CASS	LID, CASSETTE
LVR	LEVER
P-SP	P-SPRING
PANEL, CONT	PANEL, CONTROL
PANEL, FR	PANEL, FRONT
PRGM	PROGRAM
PULLY, LOAD MO	PULLY, LOAD MOTOR
RBN	RIBBON
S-	SPECIAL
SEG	SEGMENT
SH	SHEET
SHLD-SH	SHIELD-SHEET
SL	SLIDE
SP	SPRING
SP-SCREW	SPECIAL-SCREW
SPACER, BAT	SPACER, BATTERY
SPR	SPRING
SPR-P	P-SPRING
SPR-PC-PUSH	P-SPRING, C-PUSH
T-SP	T-SPRING
TERM	TERMINAL
TRIG	TRIGGER
TUN	TUNING
VOL	VOLUME
W	WASHER
WHL	WHEEL
WORM-WHL	WORM-WHEEL

サービス技術ニュース	
番号	連絡内容
G-	-
G-	-
G-	-

アイワ株式会社
AIWA CO., LTD.

9301978, 750038

Tokyo Japan